

**Derek Frost**

**Custom Furniture  
Drawings**

**BC**

**Sacks**

**Bedside Cabinets**

**Chester Terrace, London**

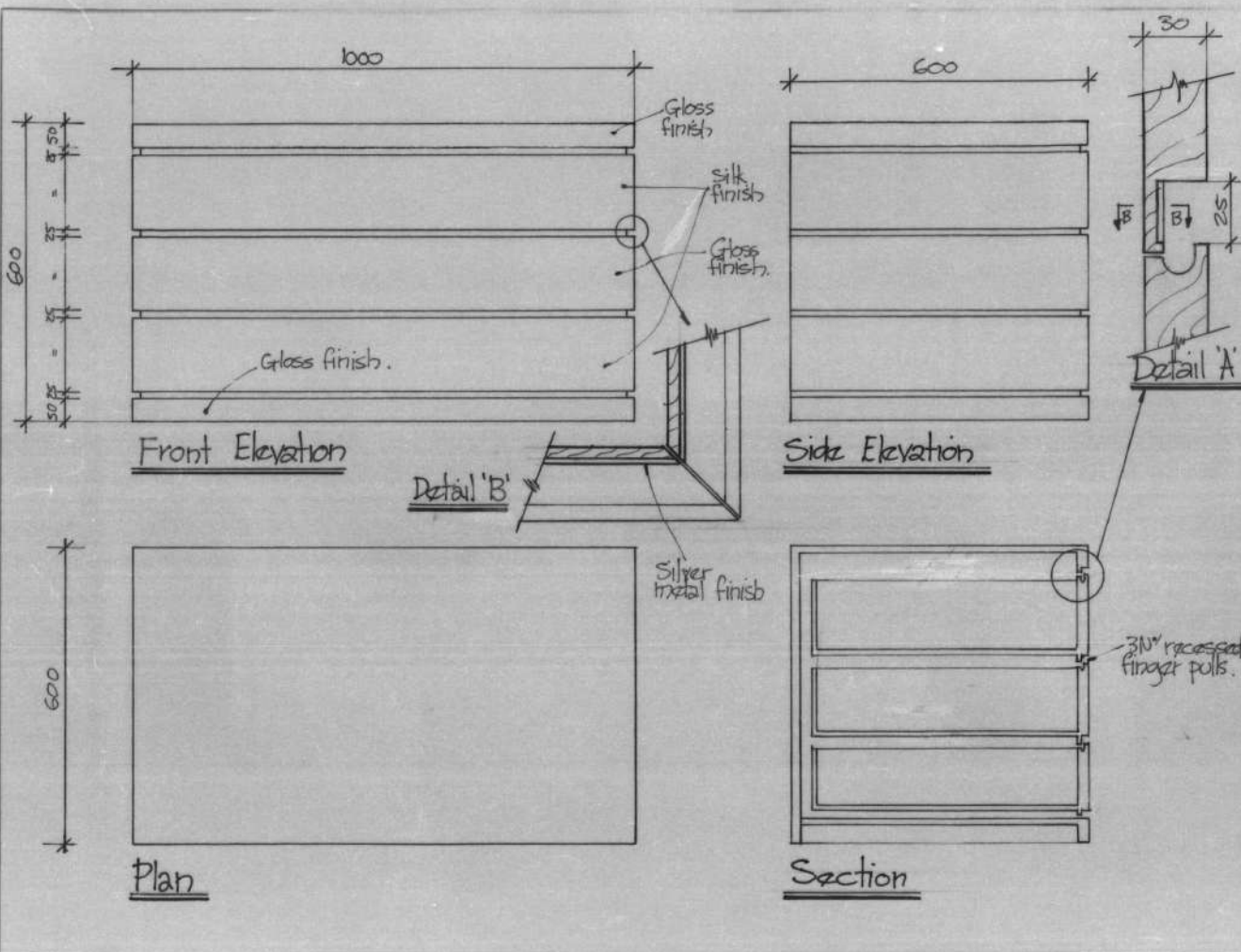

PROJECT Chester Terrace Holdings Mc.  
2N° Lacquer bedside tables.

DRAWING NO.   
 DATE July 84  
 DRAWN  CHECKED

SCALE 1:10

**DEREK FROST ASSOCIATES**  
 DESIGN CONSULTANTS  
 MORETON YARD - MORETON TERRACE NEWS NORTH  
 LONDON SW14 9NF - TELEPHONE 01-228 6228



**BF**

**Gidoomal**

**Dining Table**

**London**

Arundells

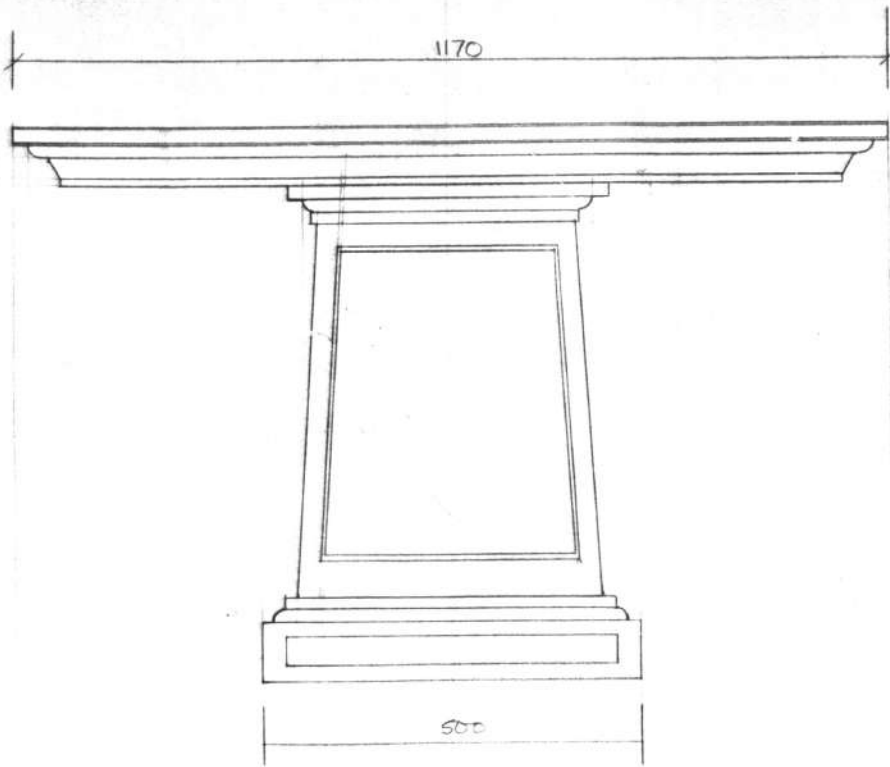
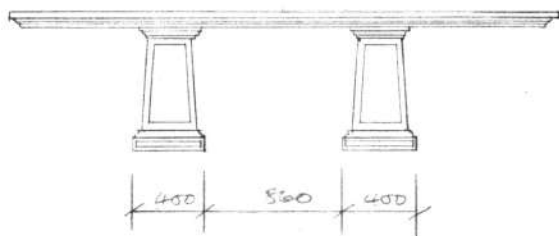
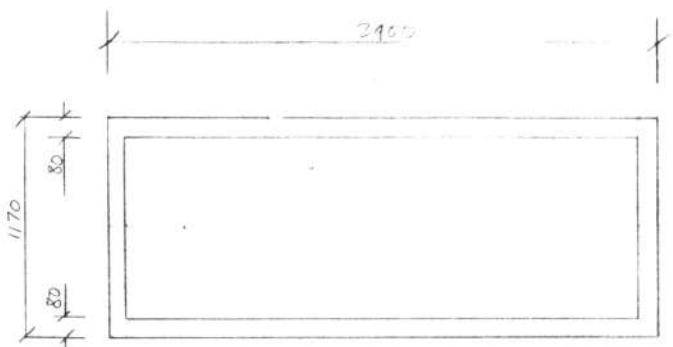

TABLE MR. BEATH
1:5 / MM / DWG 987



36° constant

TABLE NR. 125/104  
 1:20 / MM - PJM. 9.87





**BG**

**The Designer**

**Red Lacquer Chest on  
Stand**

**London**



1A.

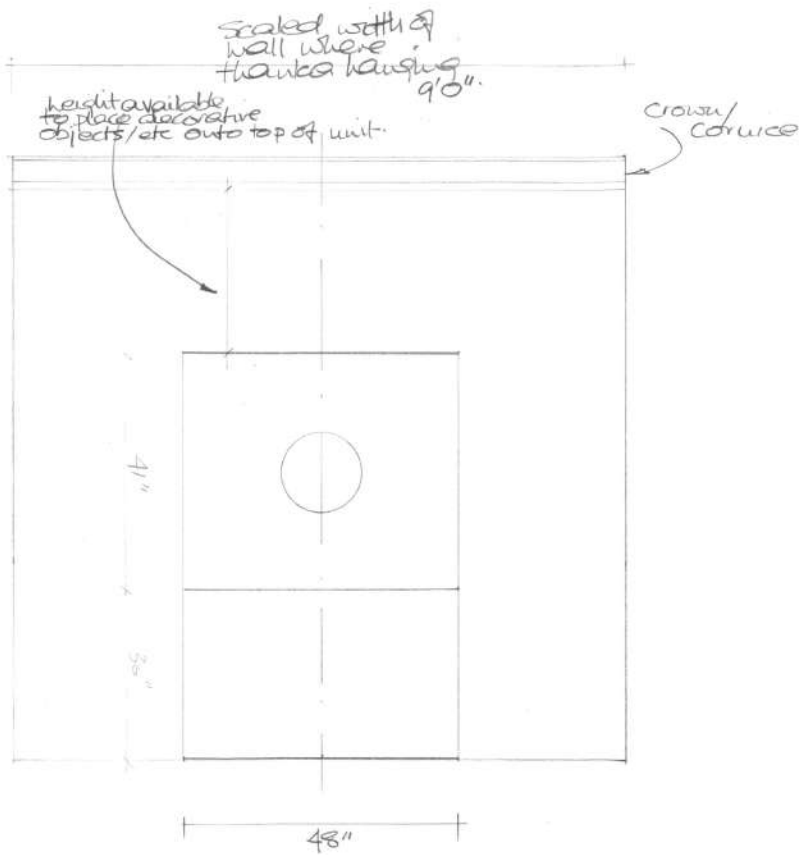

9'0" Estimated ceiling height.

35" - bar height  
 41 = 73" total h  
 48" = width  
 = my bar's scale proportion

if bar essential doors fold flat back/illumination inside + good/practical working surface

if bar, this height then "thangka" should be hung new position.

This size better contrast balance with pier table + mirror preceding it into room.

SCALE DRAWING (Estimated dimensions) of designated wall showing suitable bar size based on mmo - photo loc.

Scale 1/2" to 1'0"



**BH**

**Bune**

**Coffee Table**

**USA**

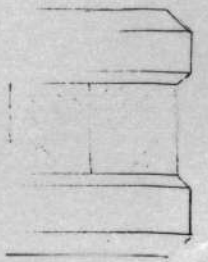
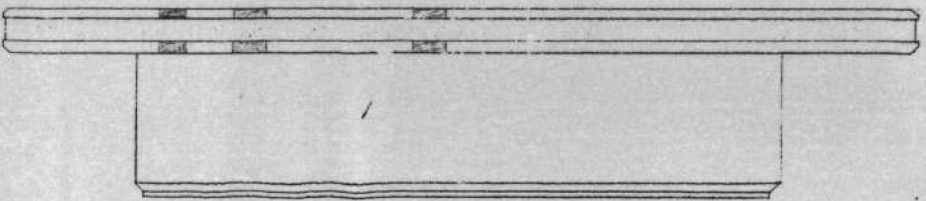
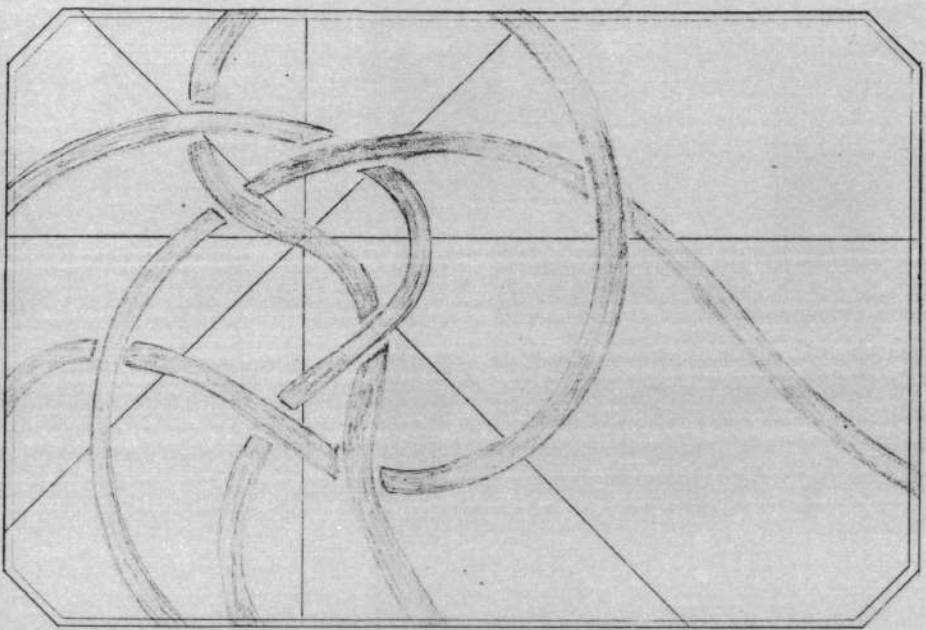

**DEREK FROST  
ASSOCIATES**

DESIGN CONSULTANTS

MOORETON YARD · MOORETON TERRACE WARRINGTON  
LONDON SW14 4NT · TELEPHONE 01-828 4278

PROJECT

COFFEE TABLE  
MR + MRS BONE.

SCALE

1/4" TO 1/0" DRAWN

DATE

7/5.

DRAWING NO.

P8/  
01.



**BI**

**Cecil**

**Triangle Cabinet**

**London**

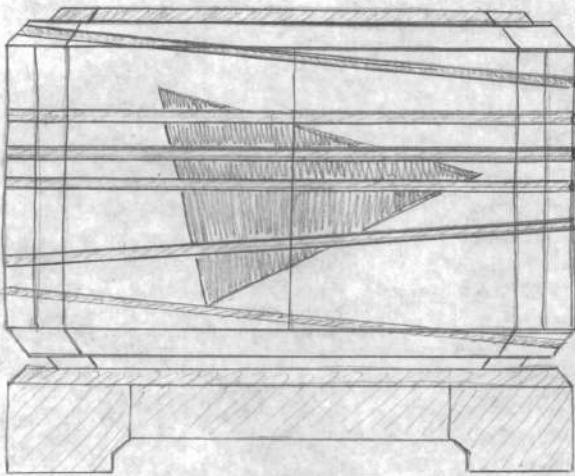

Concave/convex guide  
ebony base  
Catalpa wood?  
bubinga



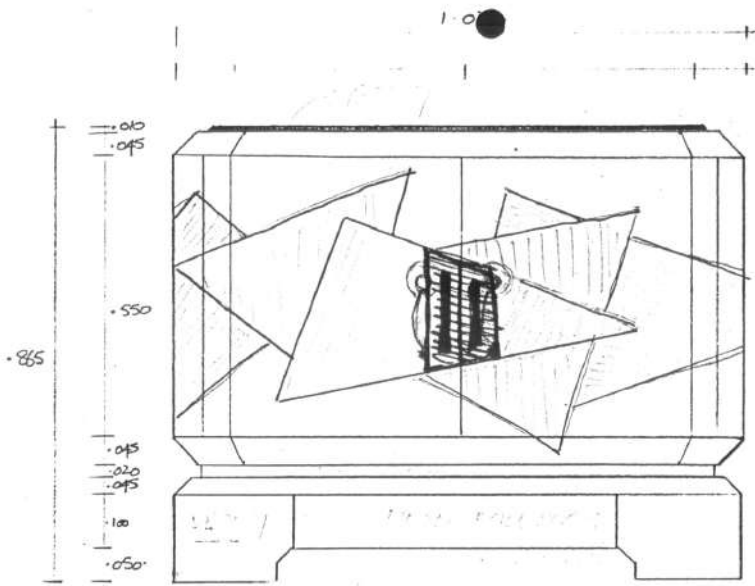

FRONT ELEVATION

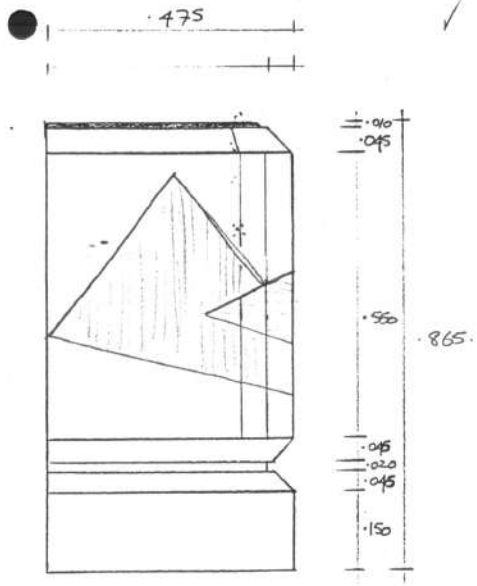

SIDE ELEVATION

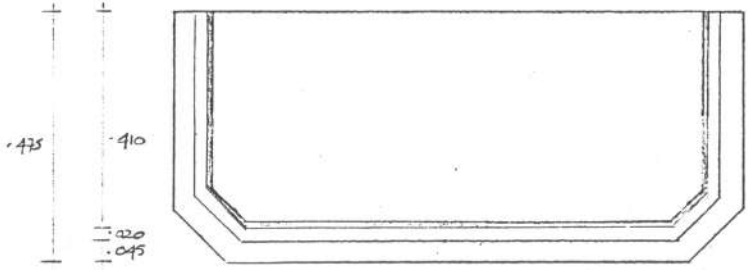

PLAN

Charles Cecil - Proposed  
Dining Room Cabinets

Scale: 1:10  
July '85.

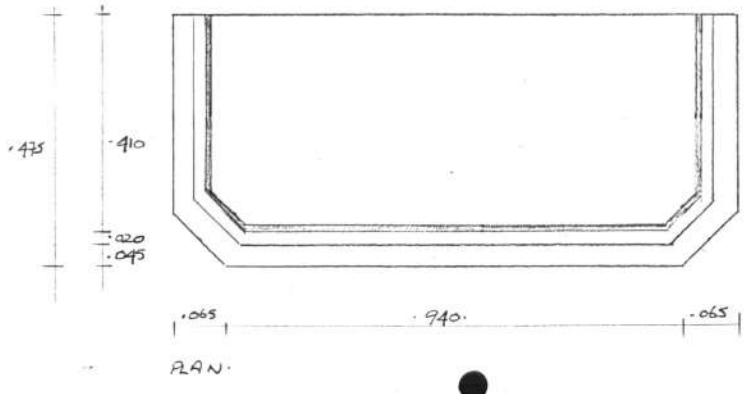
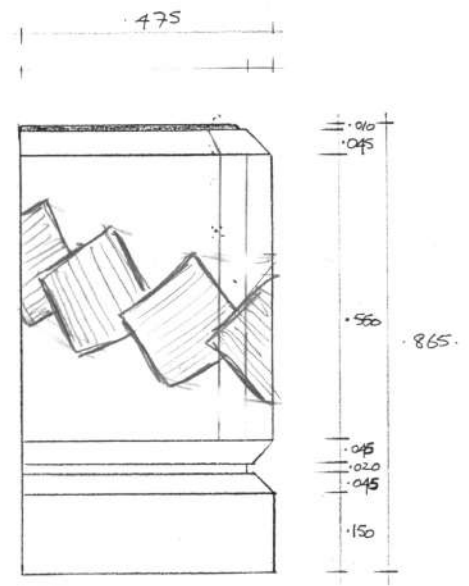
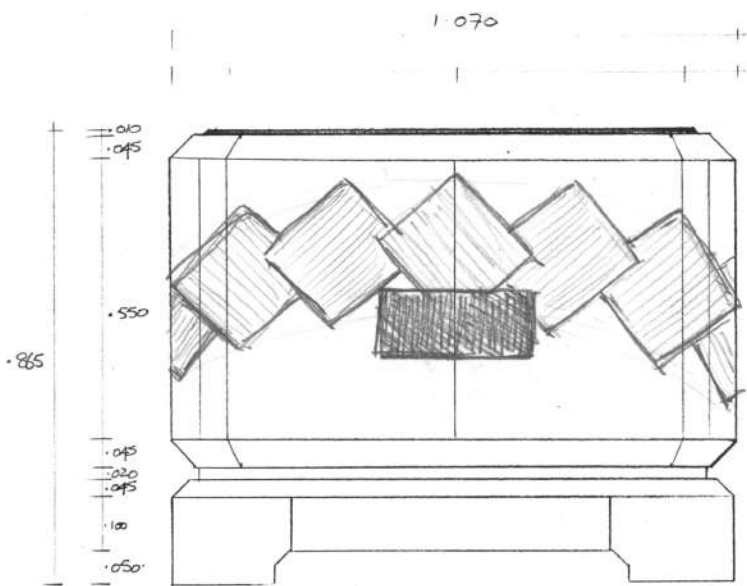

Charles Cecil - Proposed  
Dining Room Cabinets  
Scale: 1:10  
July '85.

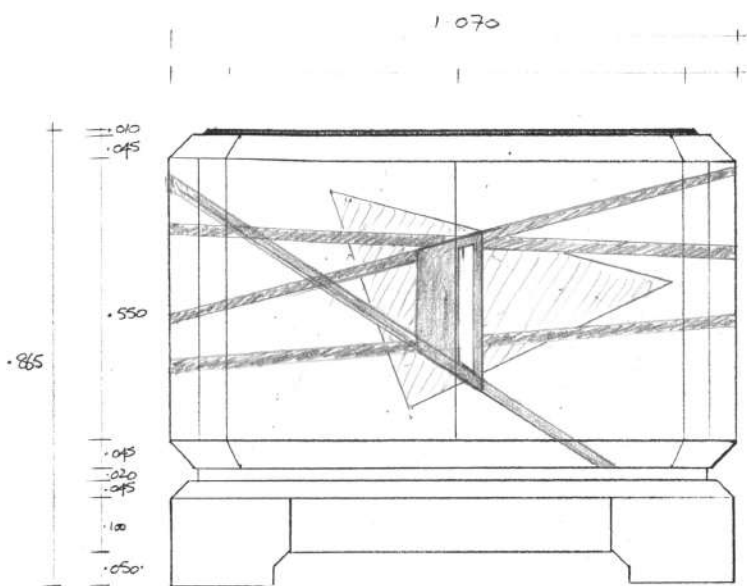

FRONT ELEVATION

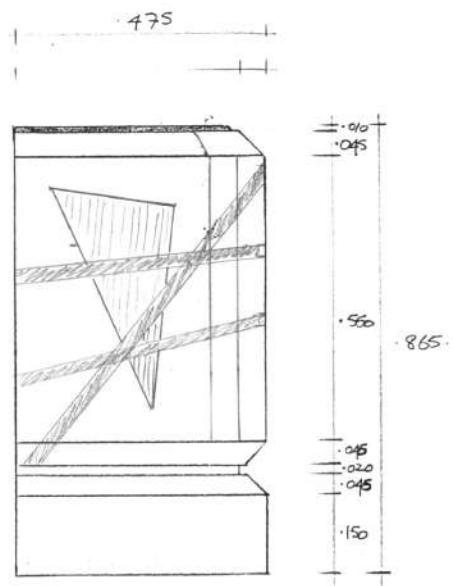

SIDE ELEVATION

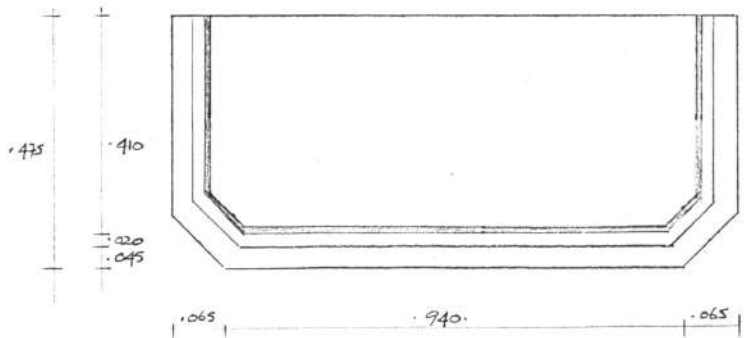

PLAN

Charles Cecil - Proposed  
 Dining Room Cabinets  
 Scale: 1:10  
 July '85.

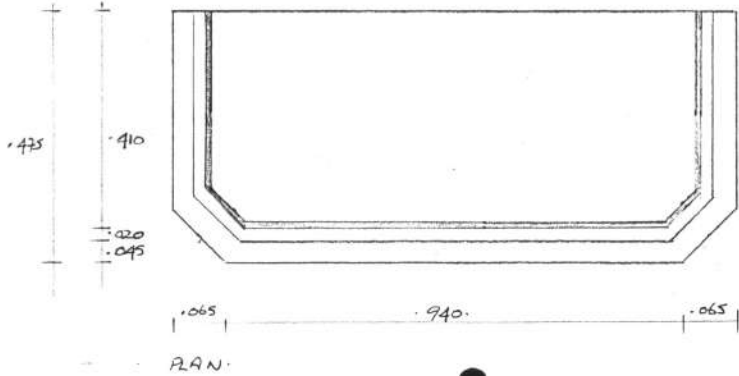
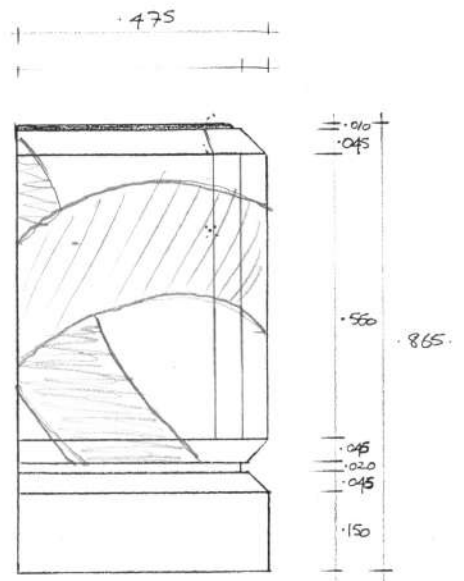
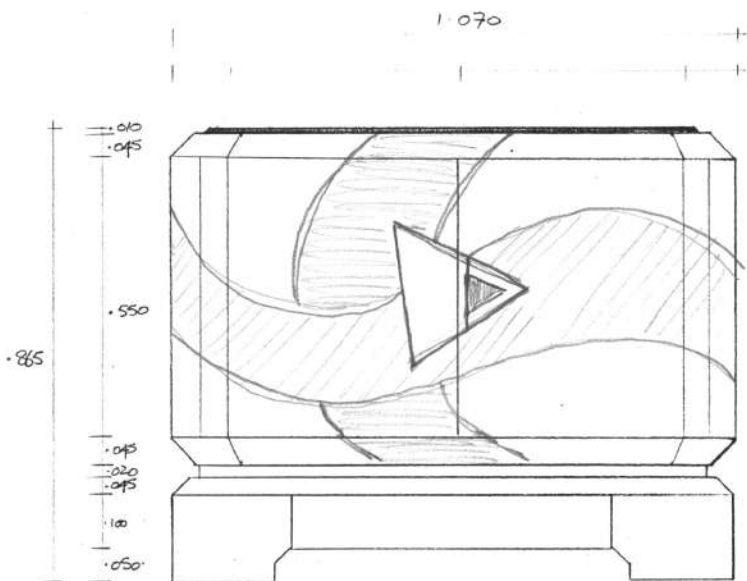

Charles Cecil - Proposed  
Dining Room Cabinets

Scale: 1:10  
July '85.



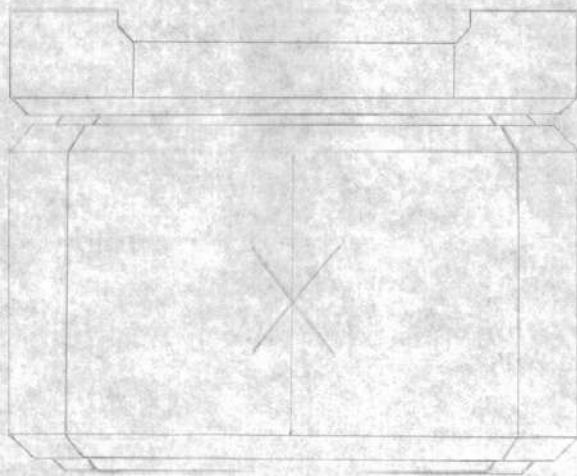

1.070

.475

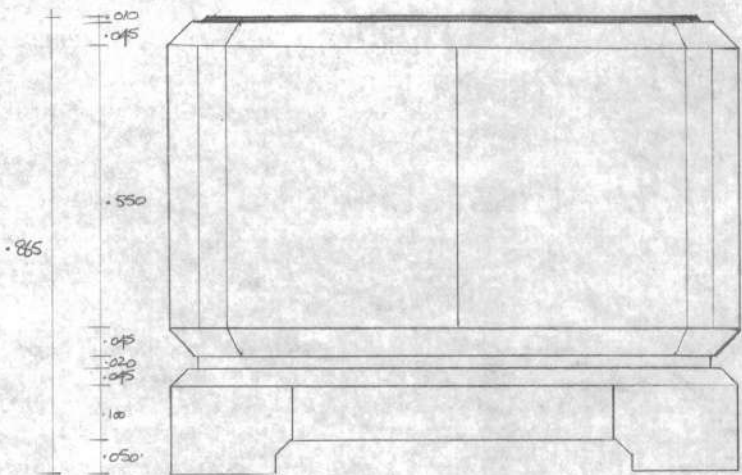

FRONT ELEVATION

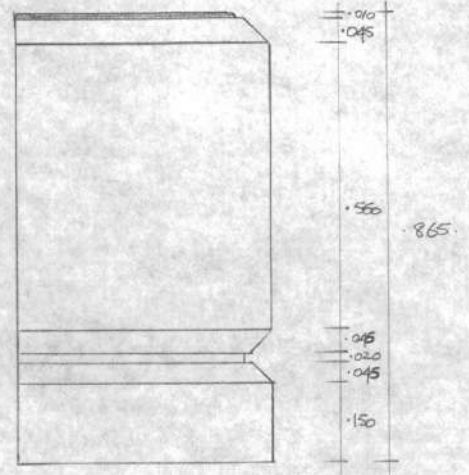

SIDE ELEVATION

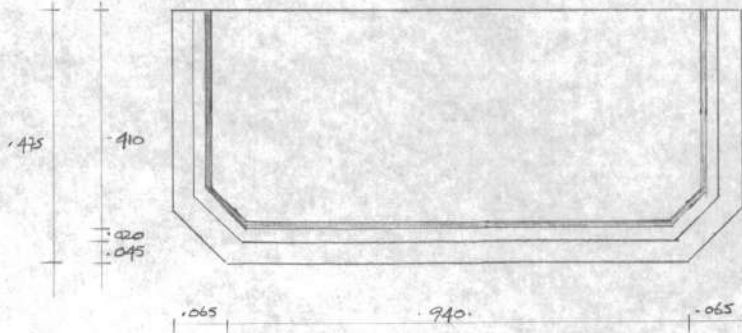

PLAN

Charles Cecil - Proposed  
Dump Room Cabinets

Scale: 1:10  
July '85.

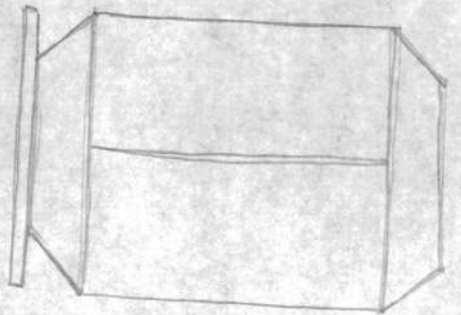
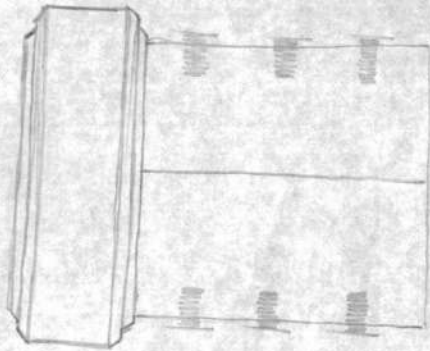
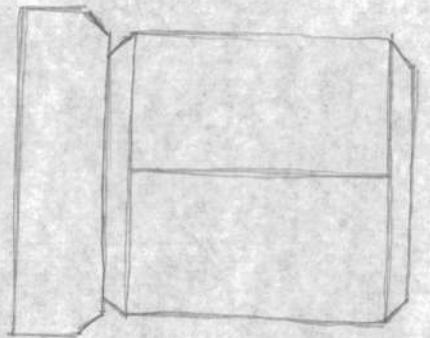
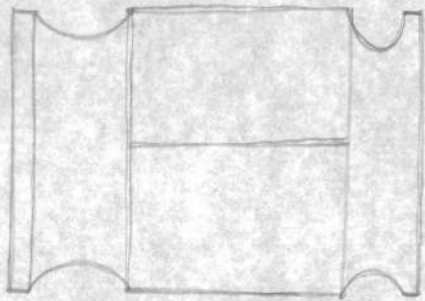
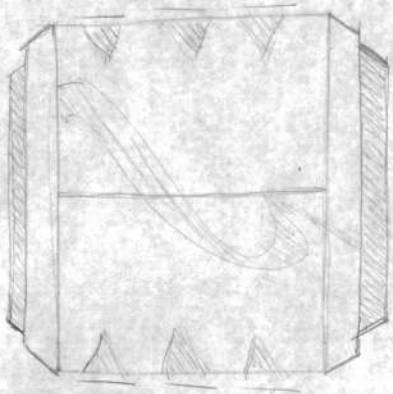



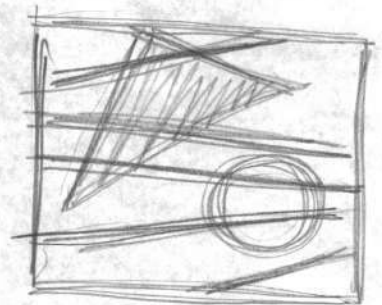
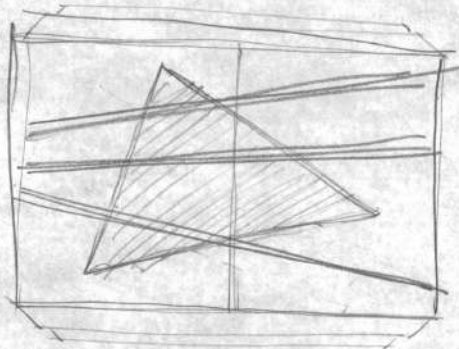
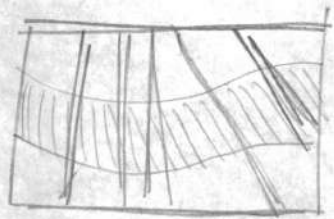
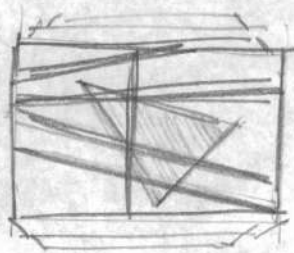

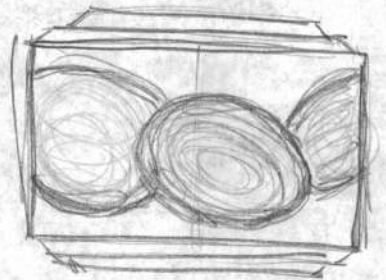
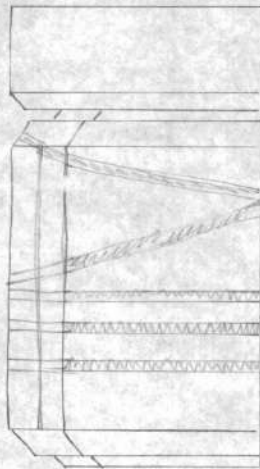
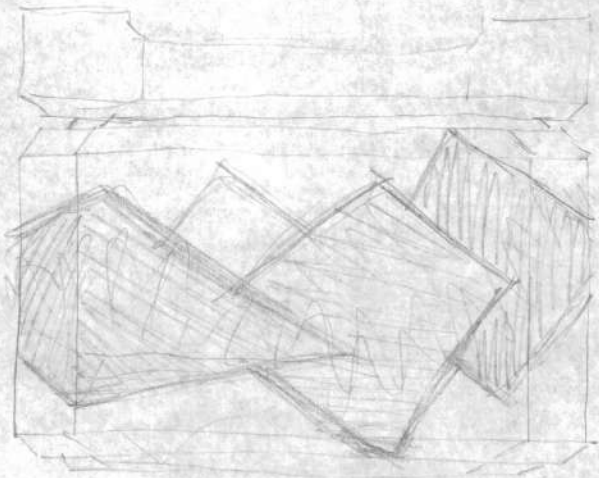
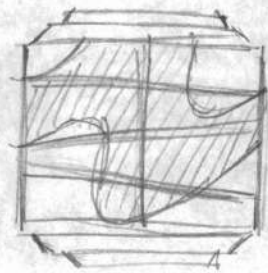
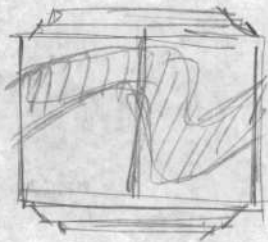
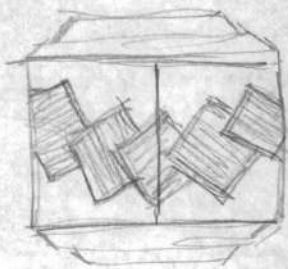

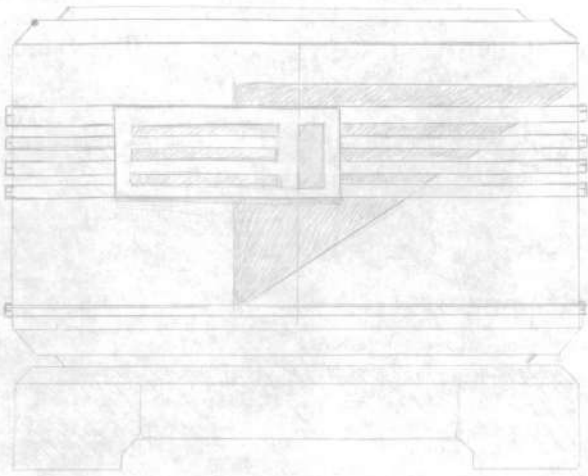

1000/1000 24 1000  
x 26 (1000)

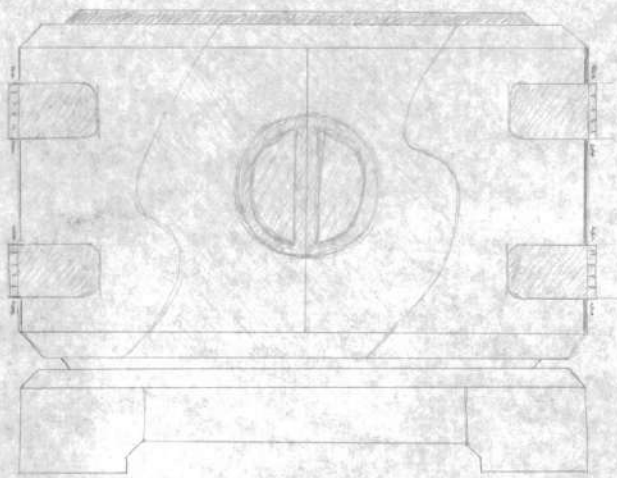



**BK**

**Salisbury**

**Ruby Box**

**Hatfield House, Herts, UK**

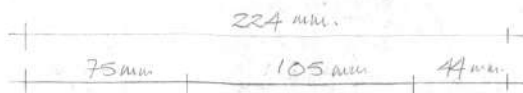

Actual measurements.

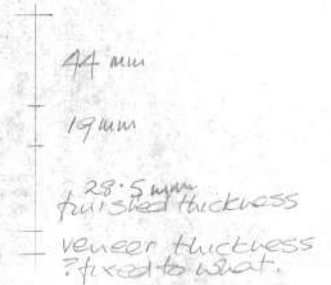
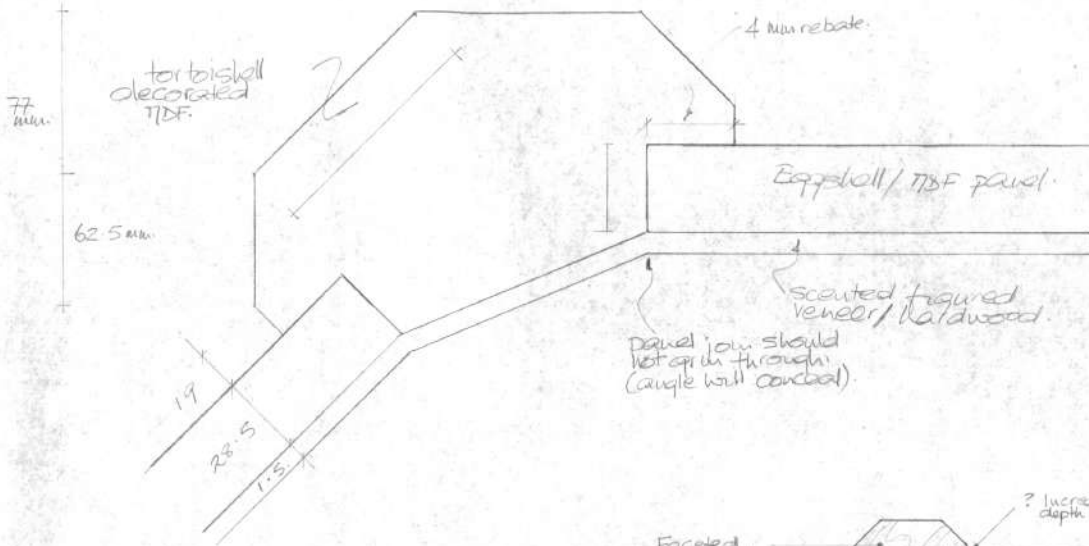

Four times scale.

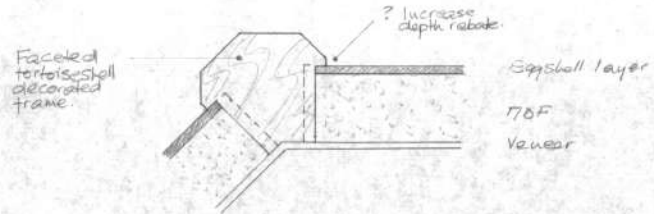

Full Scale  
Adjust x4 Dwg.

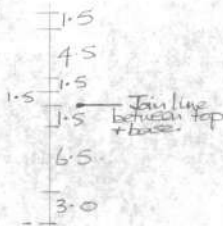
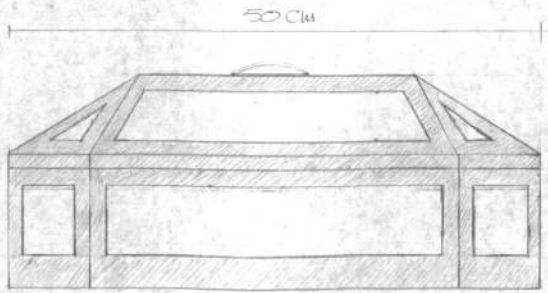
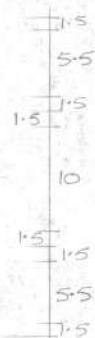
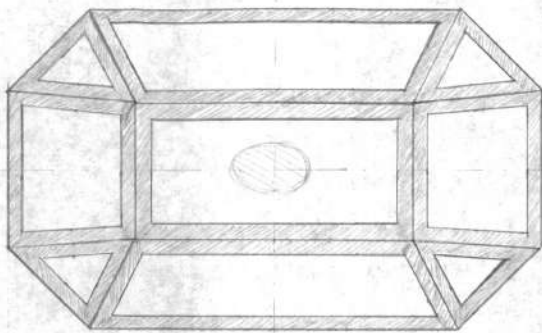
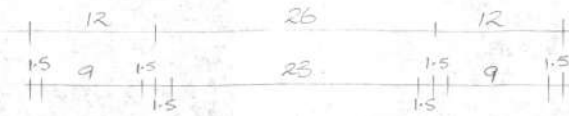

? Equilateral end triangles  
re. correct stone cut. ✓  
? Which scented wood re.  
interior. Camphor  
? Prepare/decorate before  
make up.

? Stone + mounting size  
7 x 4.5 cm.  
poss the size make worked  
marble/rebated/ no mount required.  
keep stone profile shallow curve.

Proposed detail Ruby  
Box

Scale 1:5  
date Nov 85.





**BM**

**Sassoon**

**TV Cabinet**

**Chester Square, London**

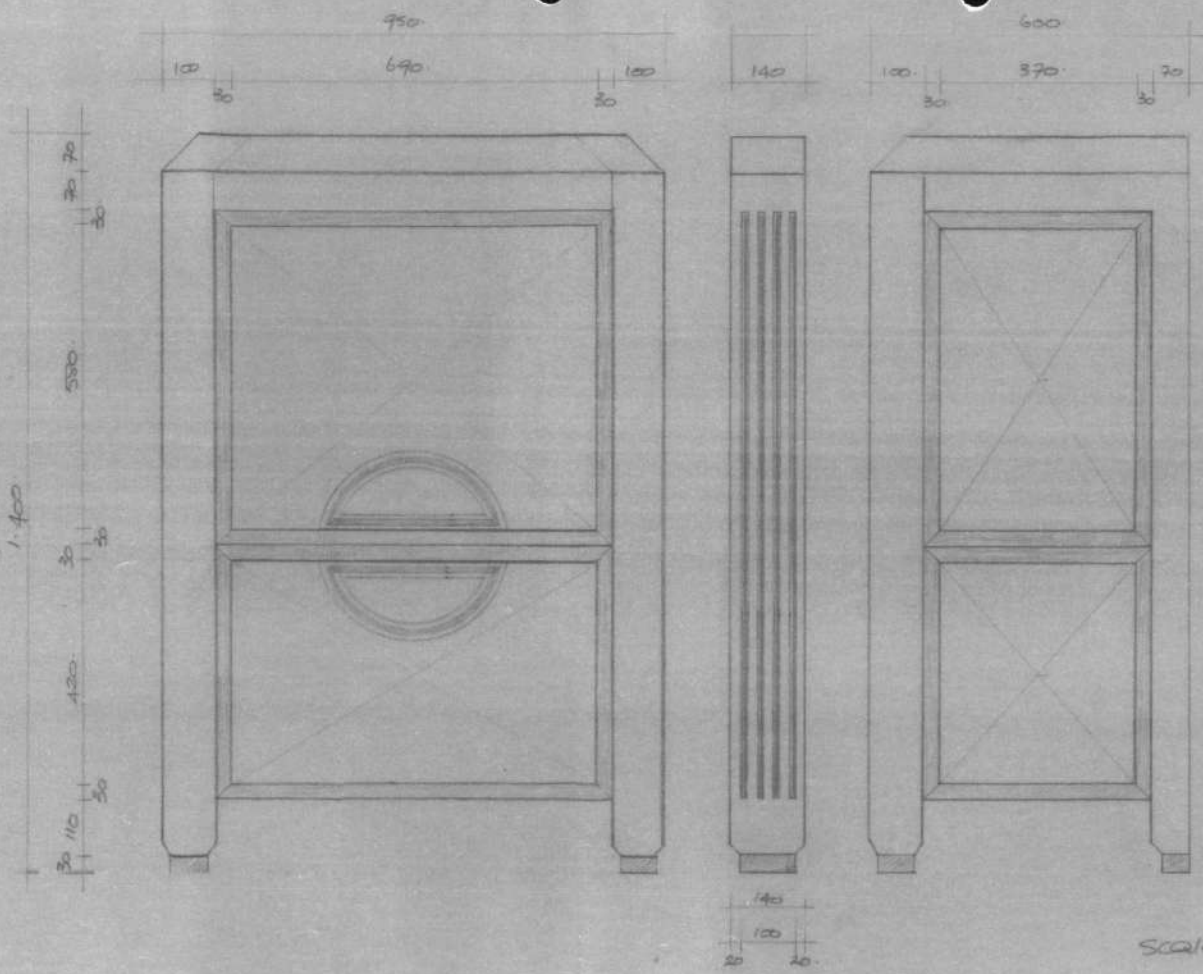



**BO**

**Ducas**

**Dancing Desk 1**

**London**

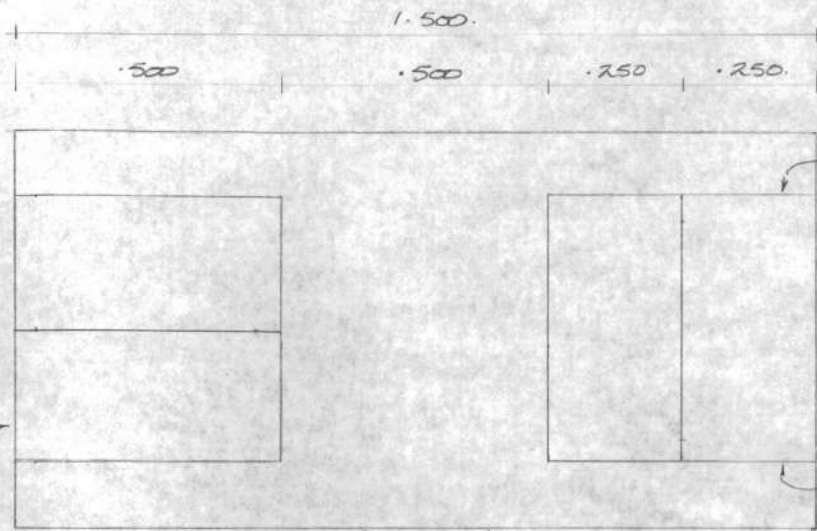

PLAN

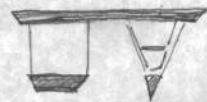

top + base  
 colorcore  
 spectrum red  
 velvet 7845.  
 cloud blue  
 velvet 7855.

Dancing Desk for  
 Diamet, Ducas

scale 1:10  
 date Aug '85.

KNOCKDOWN FIXING  
 Cellulose or  
 Cellulose/Laminate Finish  
 on MDF.  
 Drawer or open shelf versions

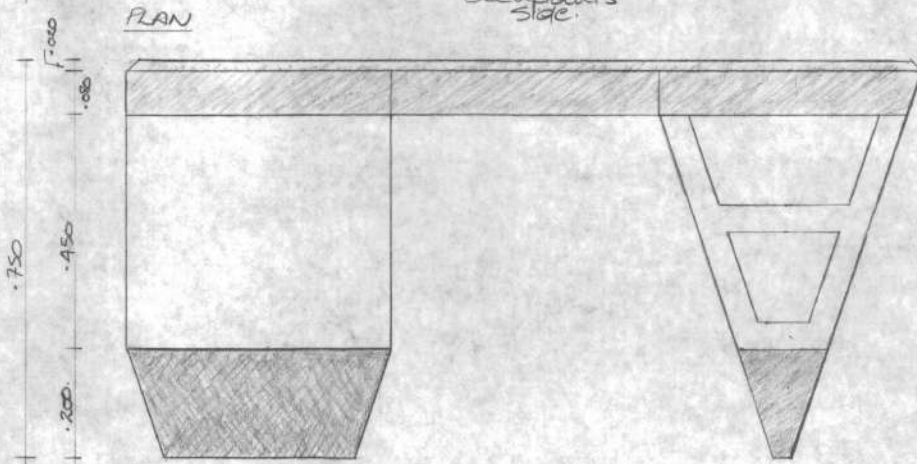

OCCUPANTS FRONT ELEVATION

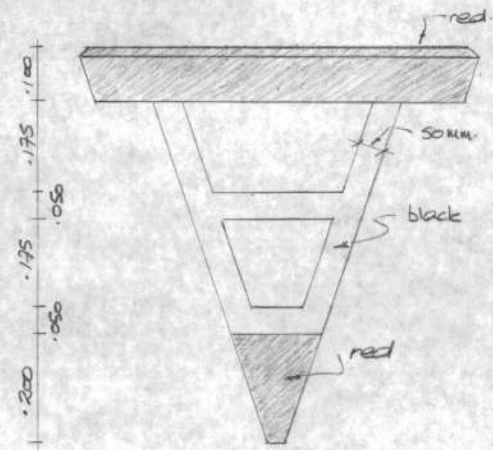

LEFT SIDE ELEVATION



**BP**

**Designer**

**Dancing Desk 2**

**London**



74h

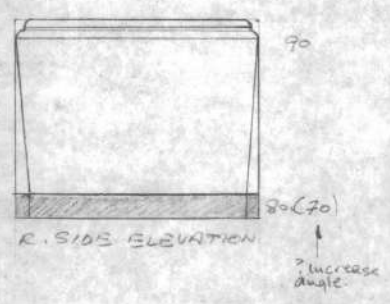
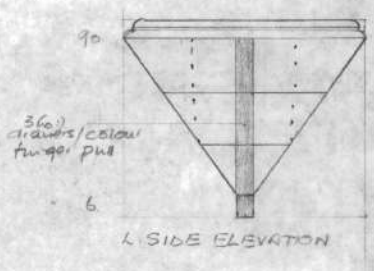
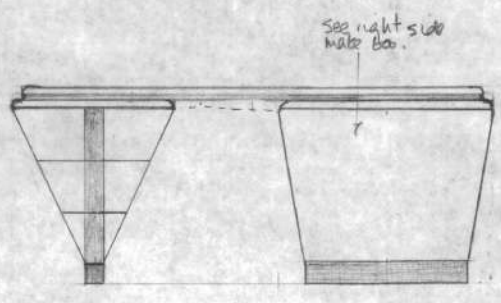
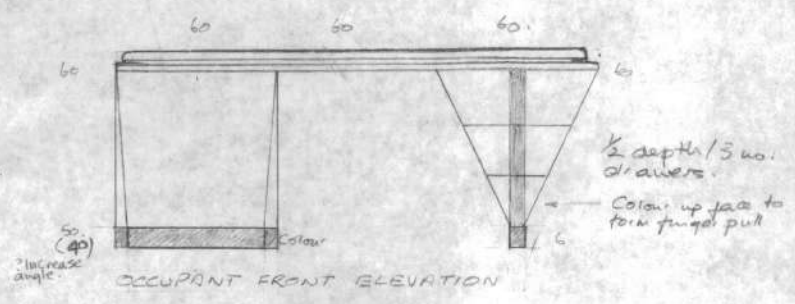
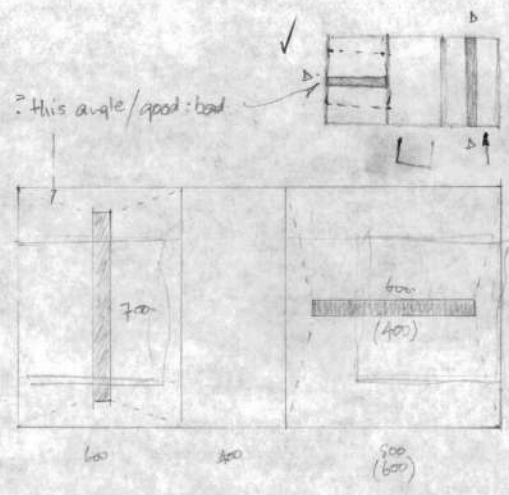

Drawers lay on type / mitre join to flanks



Visitor Elevation



**BR**

**Cecil / Heath**

**Racing Chairs**

**London**

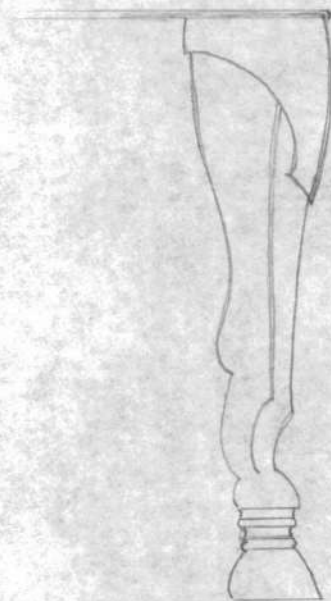
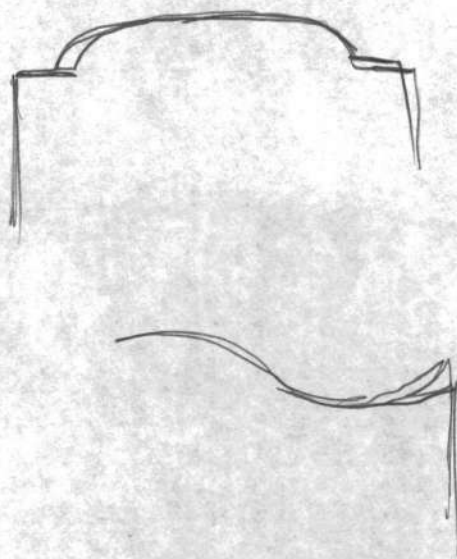

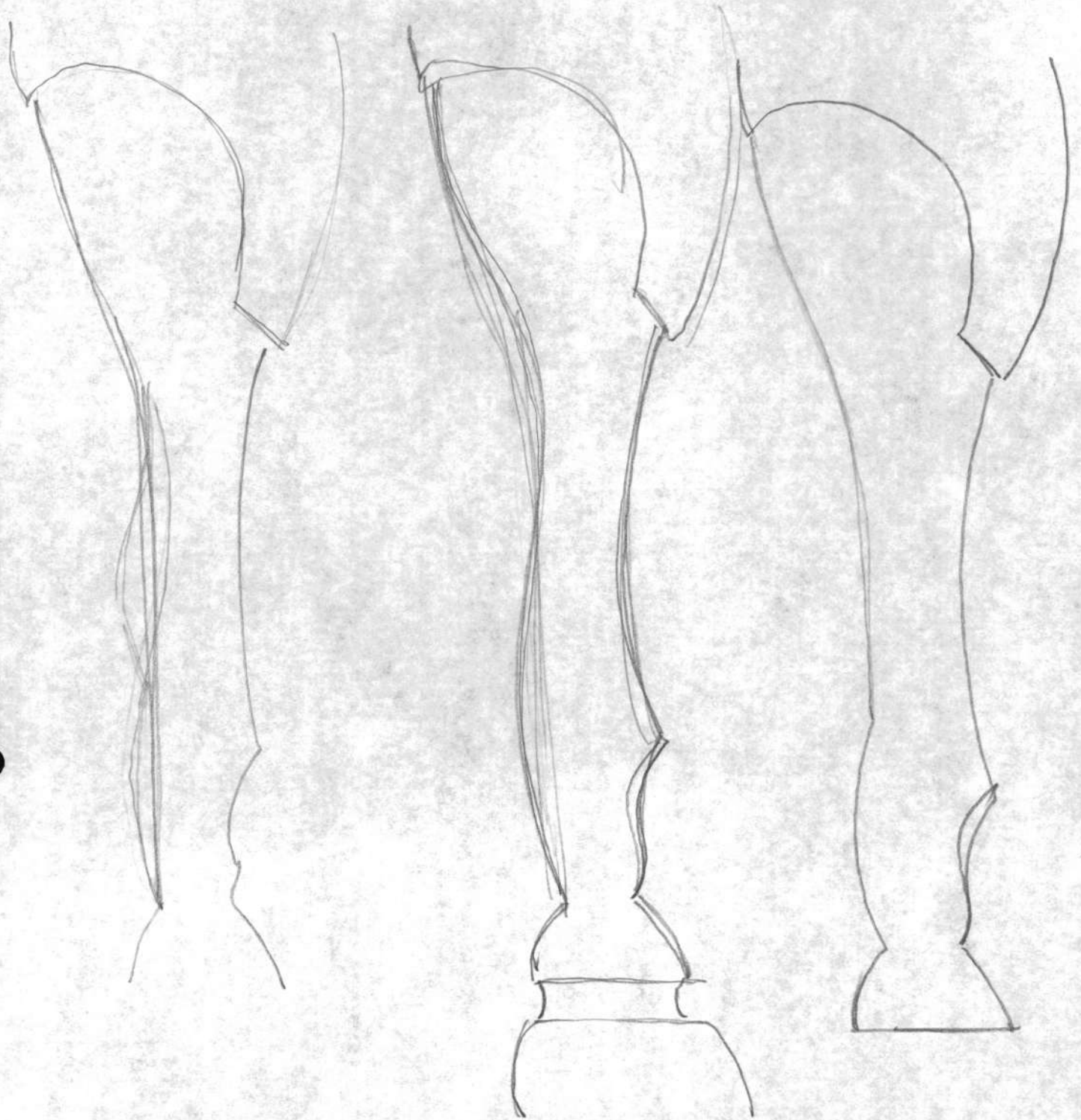

How much  
express diagonal  
or forward lean?

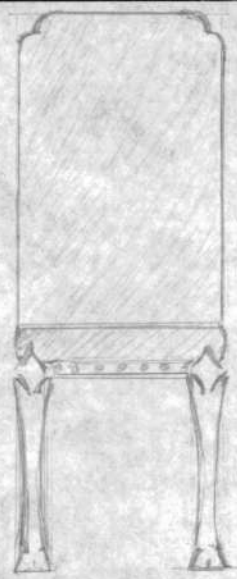
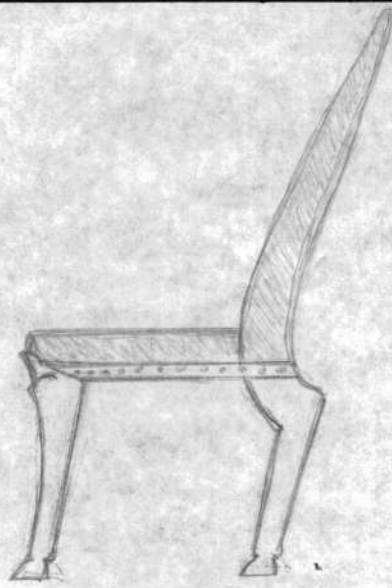

Band  
Carve together or 3 no: hardwood strips +  
mahogany (alternative)  
red  
mahogany (alternative) - V-sharp shape  
like seam - maybe showing back only (checky  
like stacking seam)

Fine woven fabric

wrap around seat with fine mahogany or  
contrast lower band - ? carved / instead of  
or below railing?

Hope / Egyptian  
Gansbarthel / Shure  
Chair

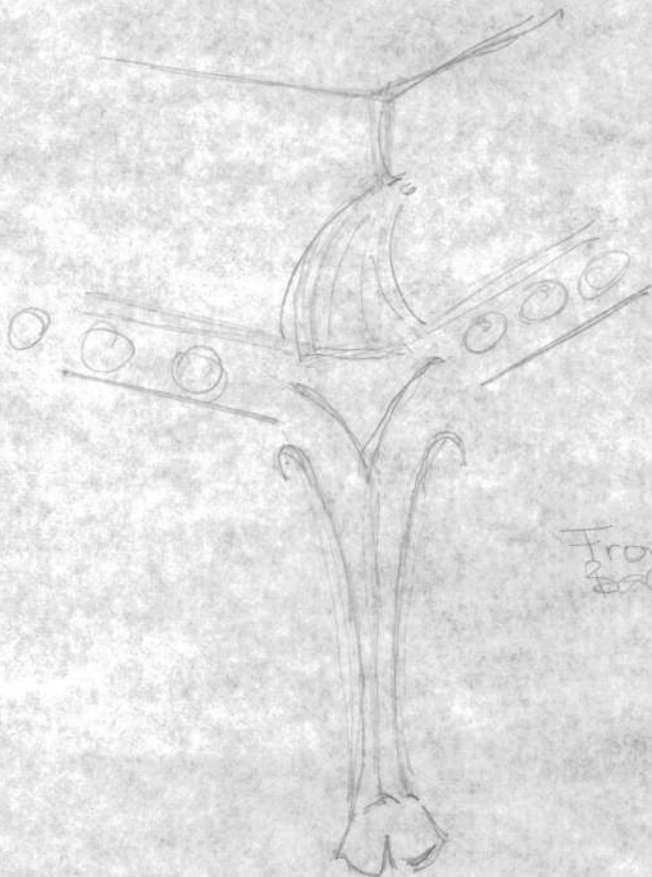

Front leg out at 45° diagonal  
Back leg straight

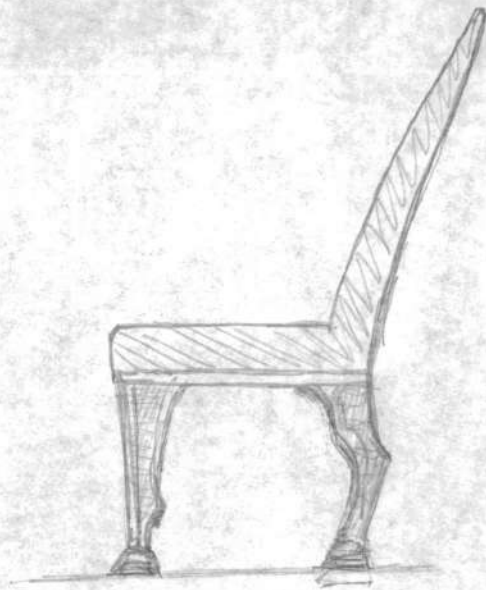
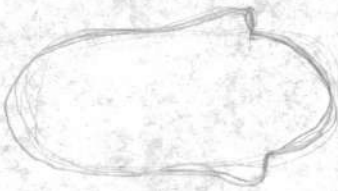
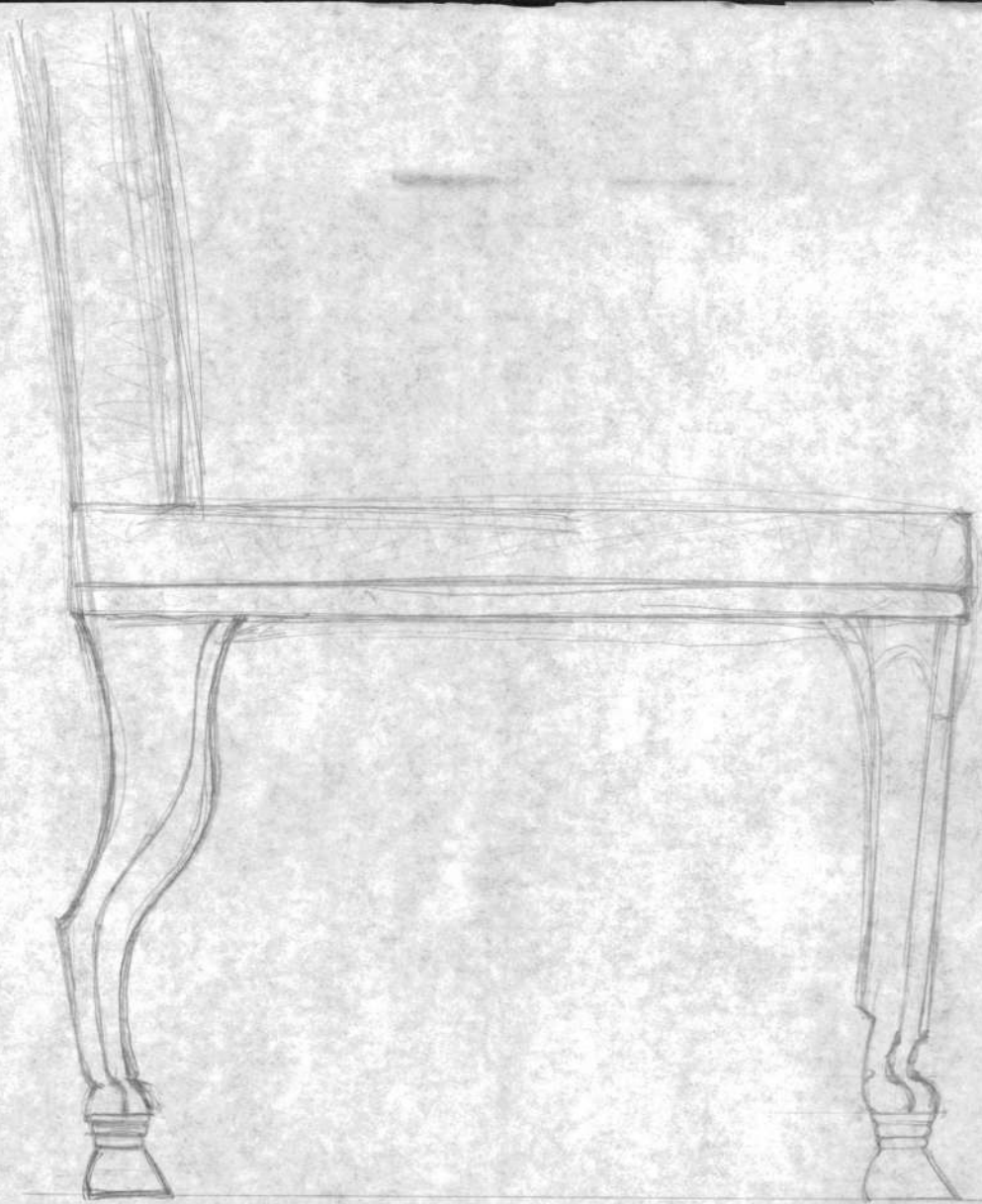

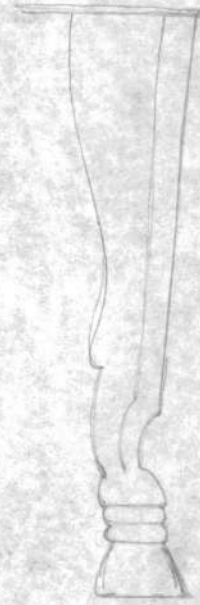



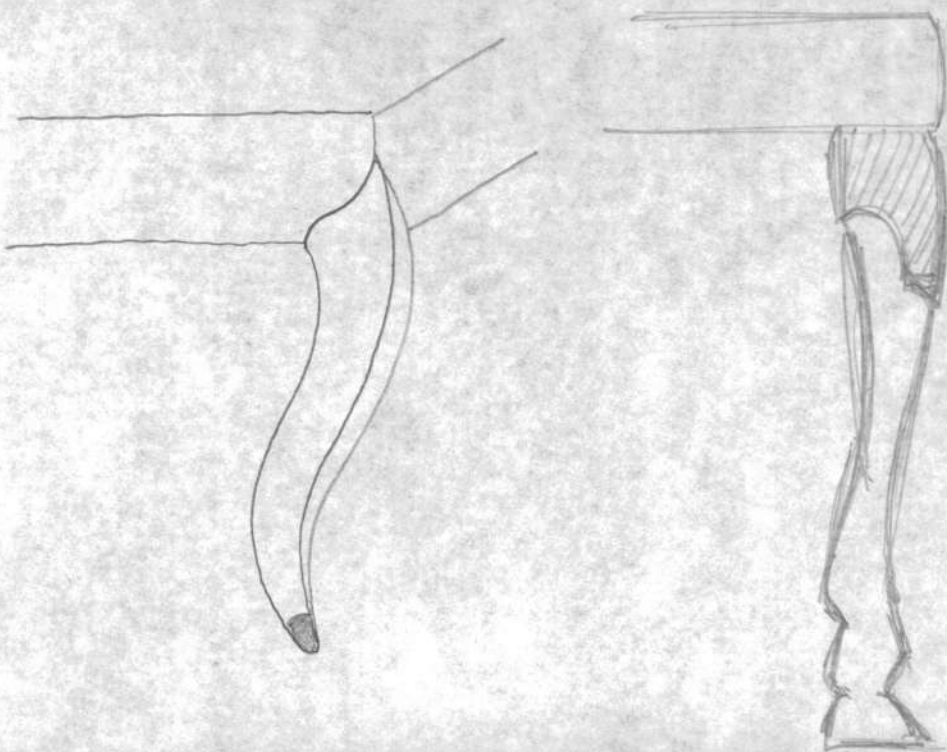
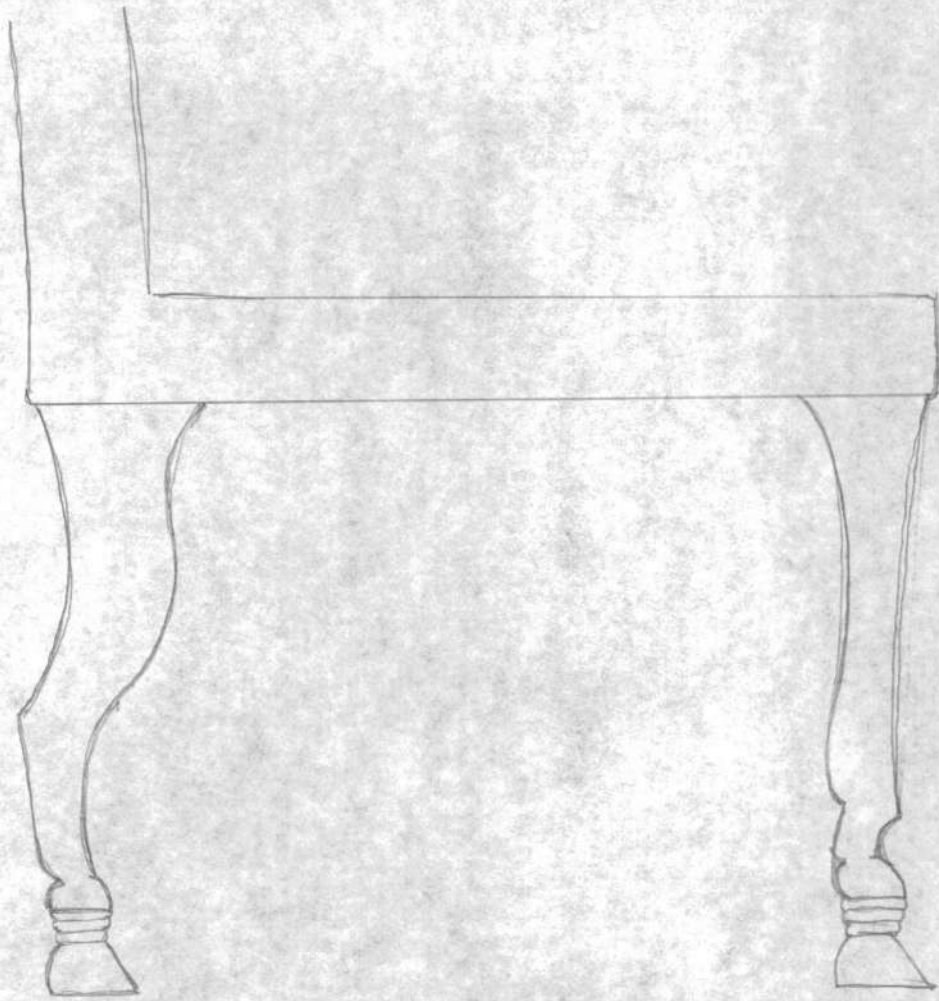



**BS**

**Morris**

**Scarf Console**

**London**

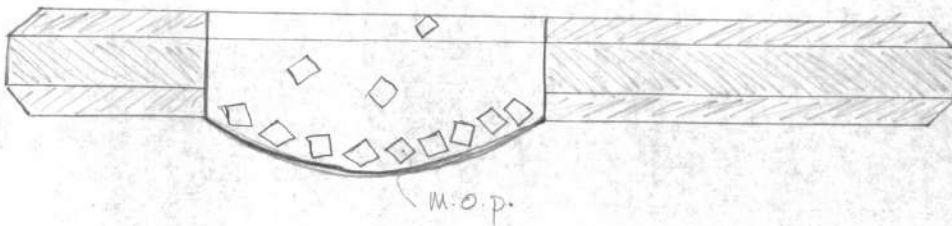
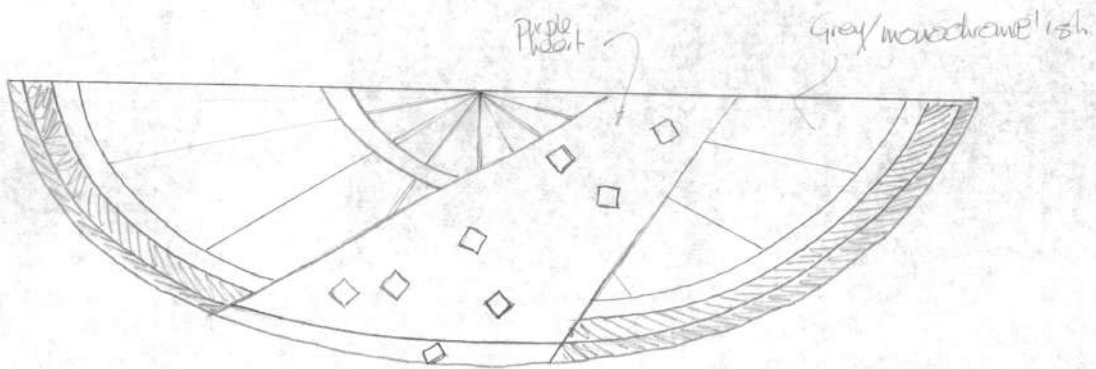

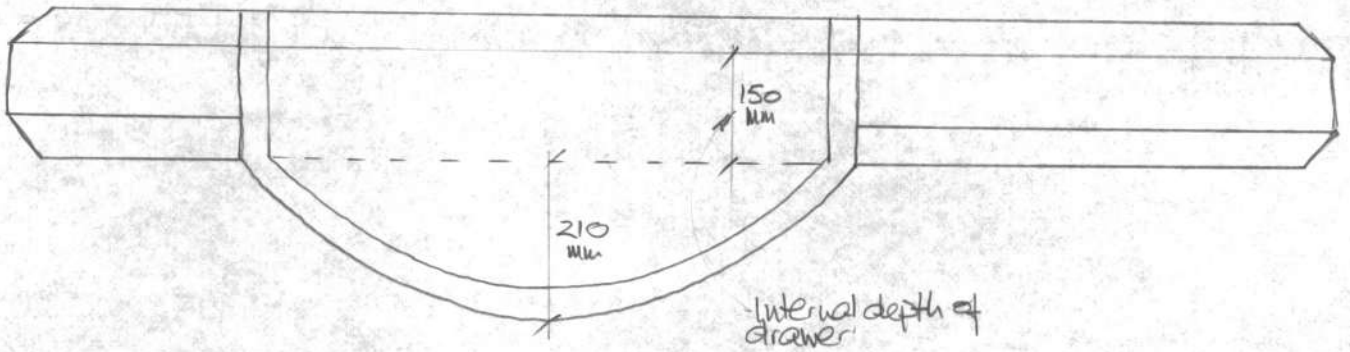
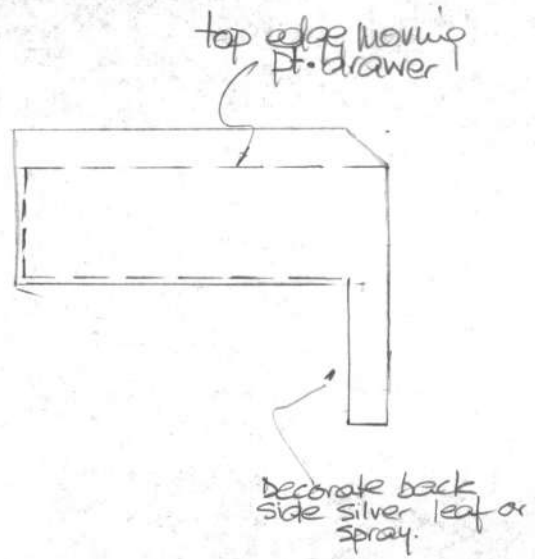
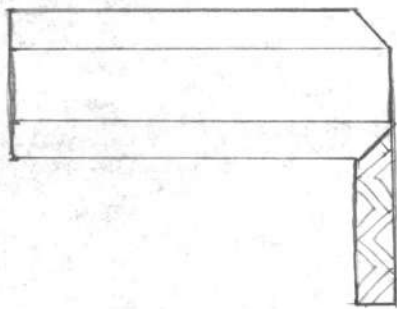

Scale 1:10  
Date Nov '85

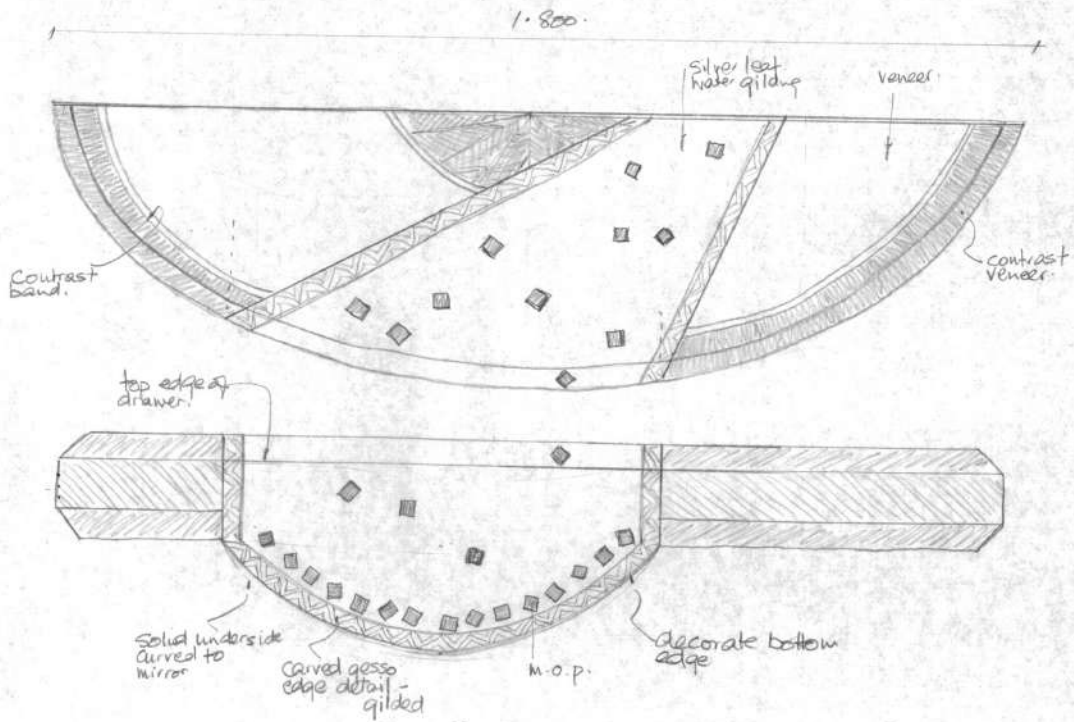



**BT**

**Designer**

**Bedside Tables**

**London**



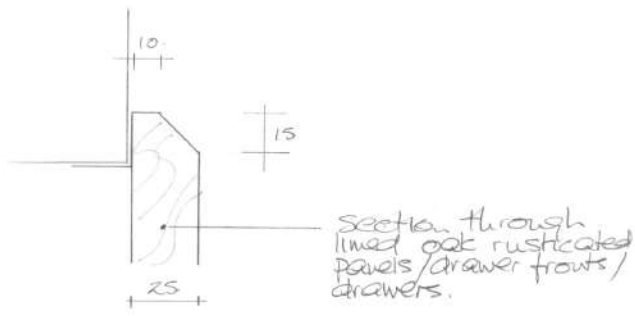
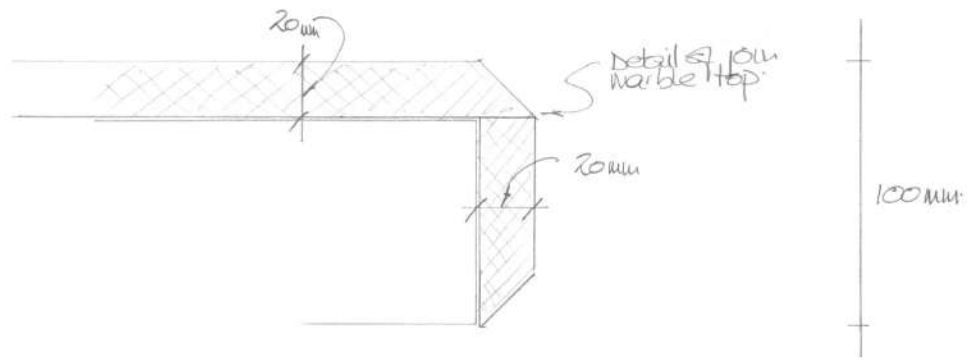

Detail of marble pm  
bedside tables + oak  
fronts.  
1/2 scale  
date July '86.  
client: YARD.

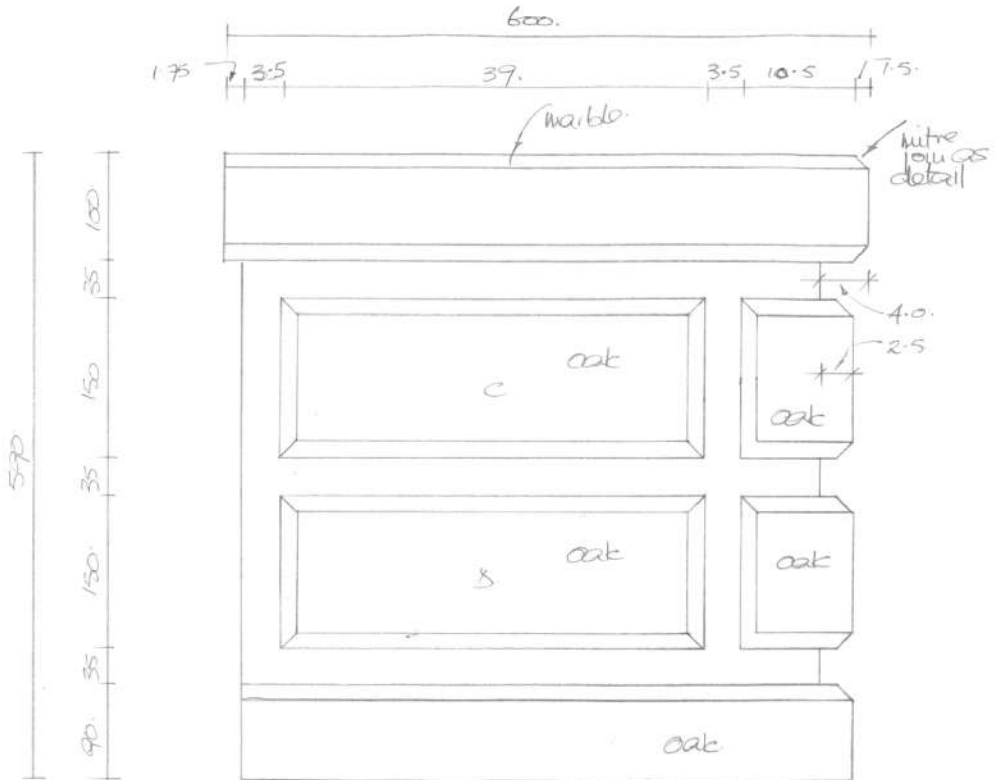

c + d on both sides to be opening doors with concealed finger pulls.

scale 1:5  
date July '86  
client: YARS.

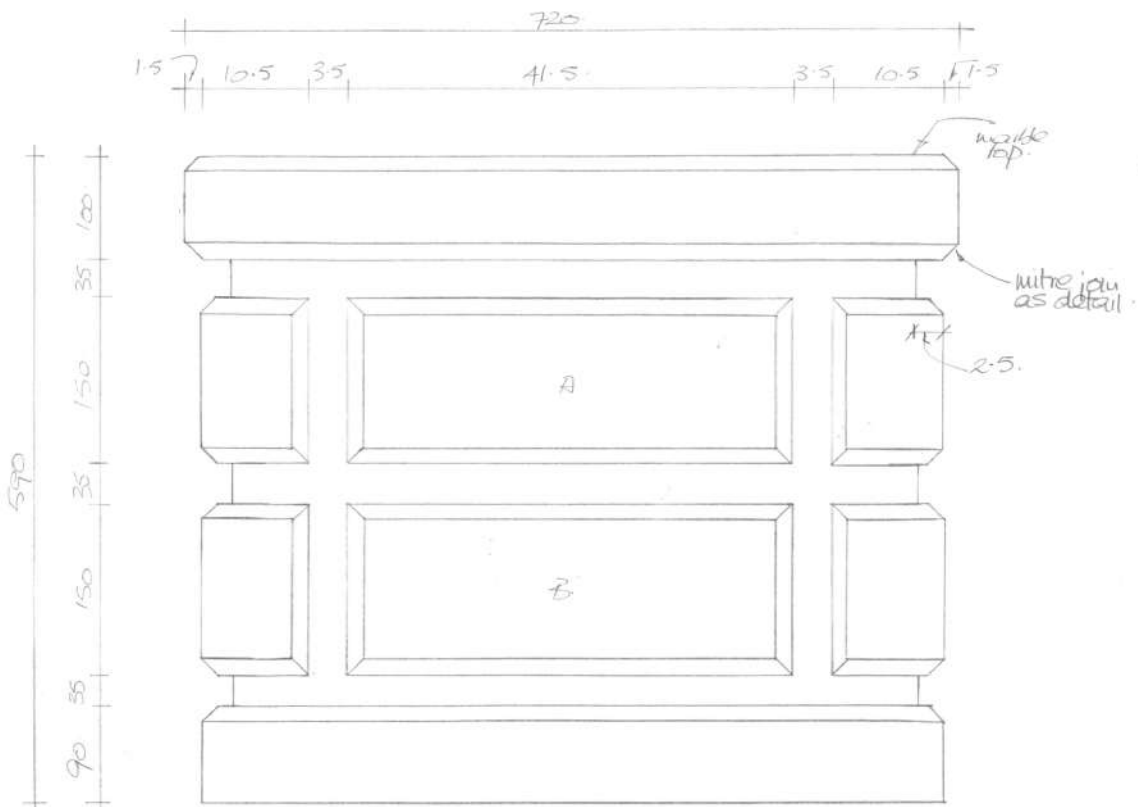

A+B - 2 (no)  
 opening drawers  
 with concealed  
 finger pulls

Scale: 1:5  
 date: July '86.  
 client: YARD.

