

BV

Abrahams / Yang Chen

Horn Chest

London

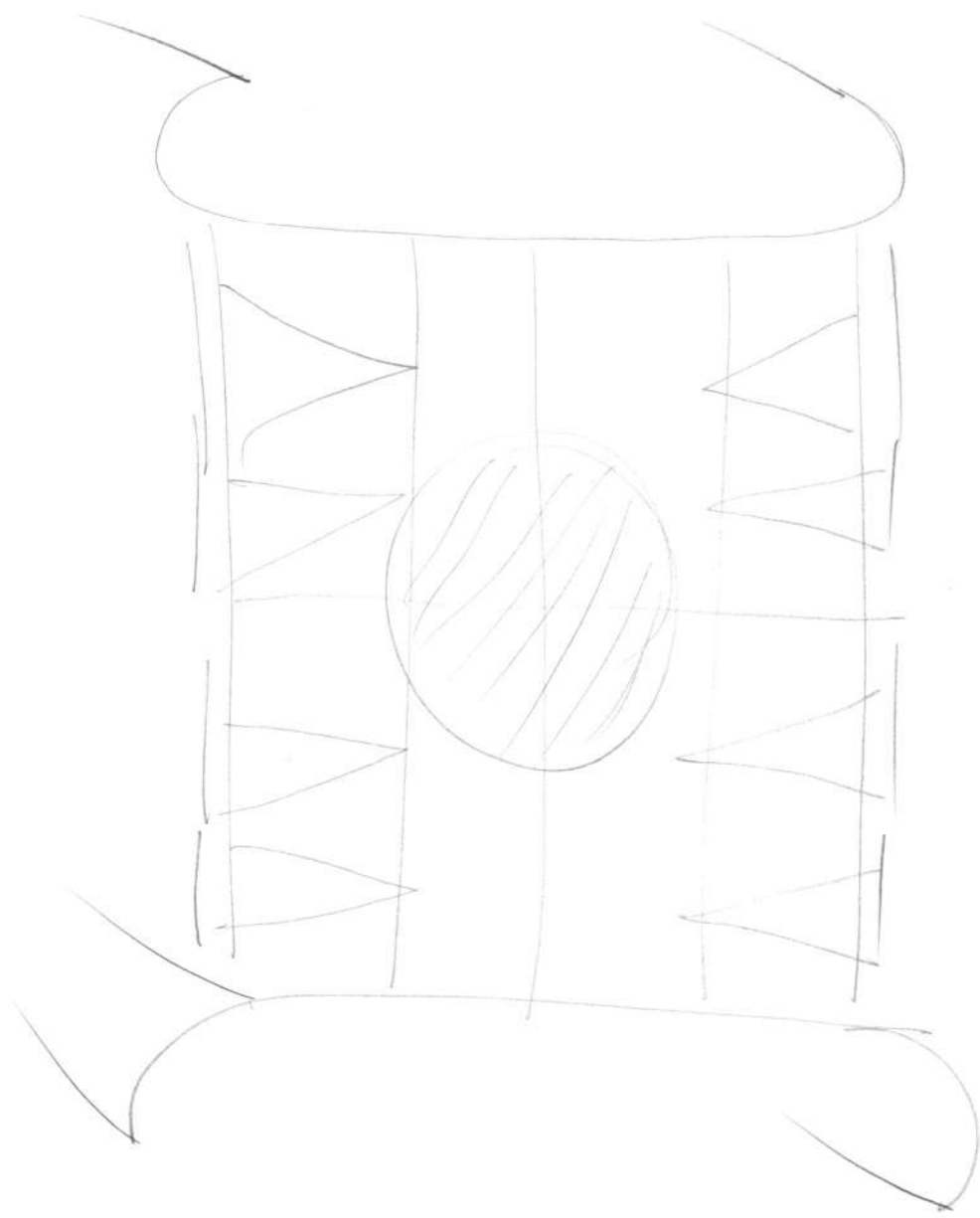

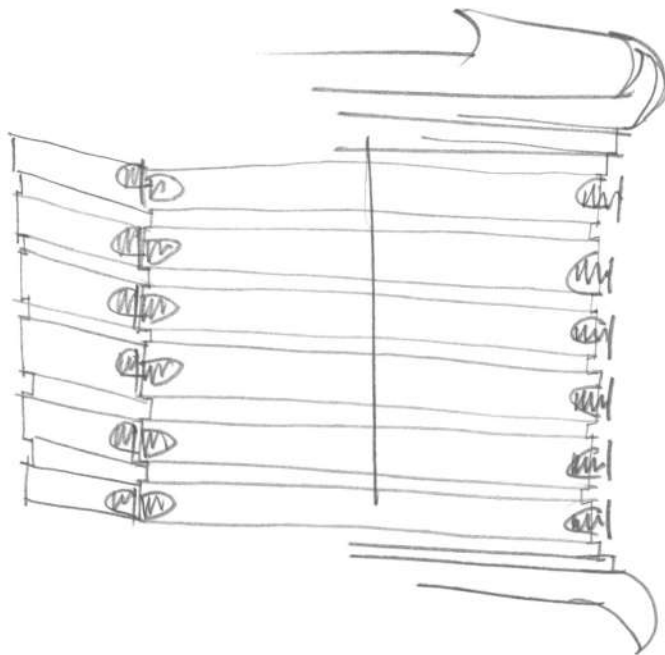
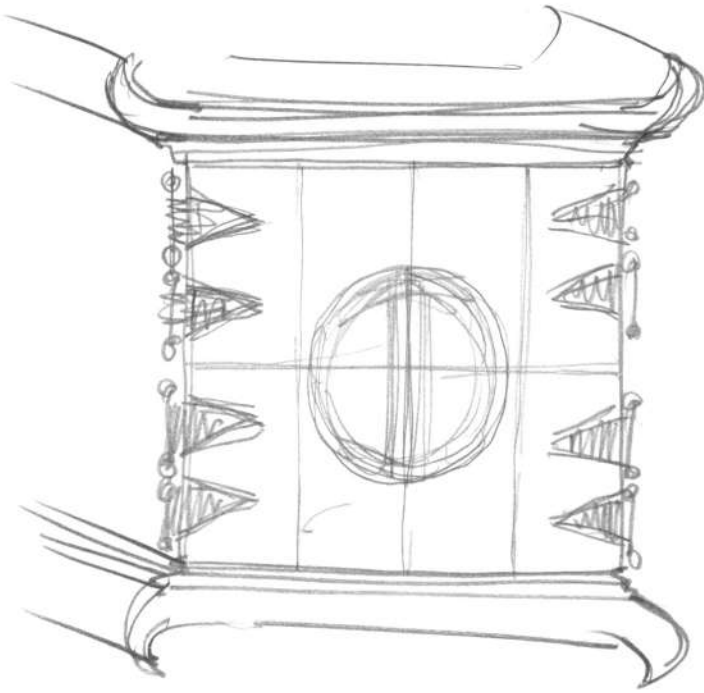

no main handle
variety



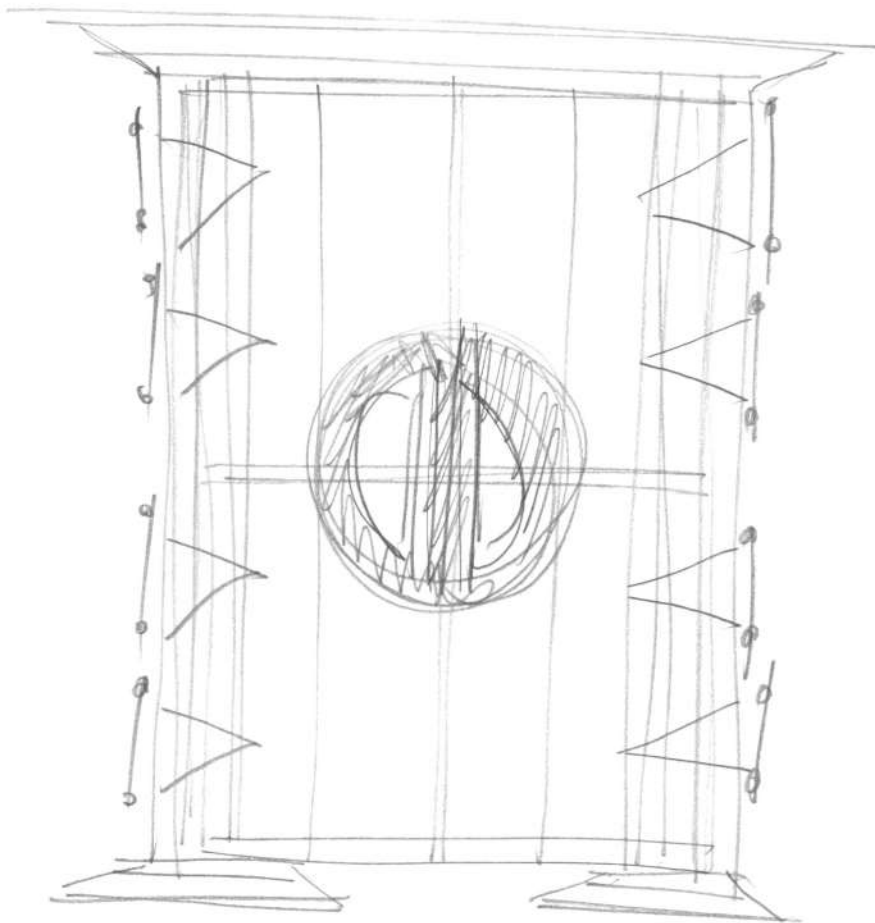

less bizarre/
oriental
alternative
still strong
personality

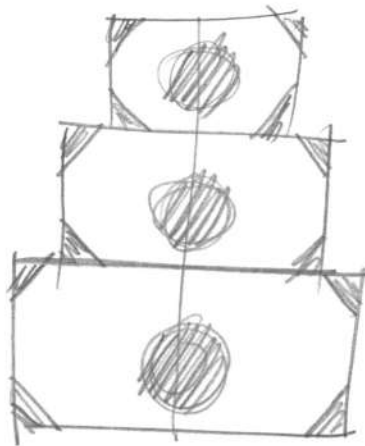

alternative

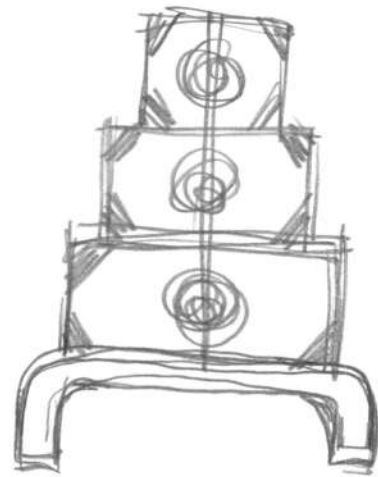

Where semi-lune table
5'0" / 1'0" x 9'0" diam.

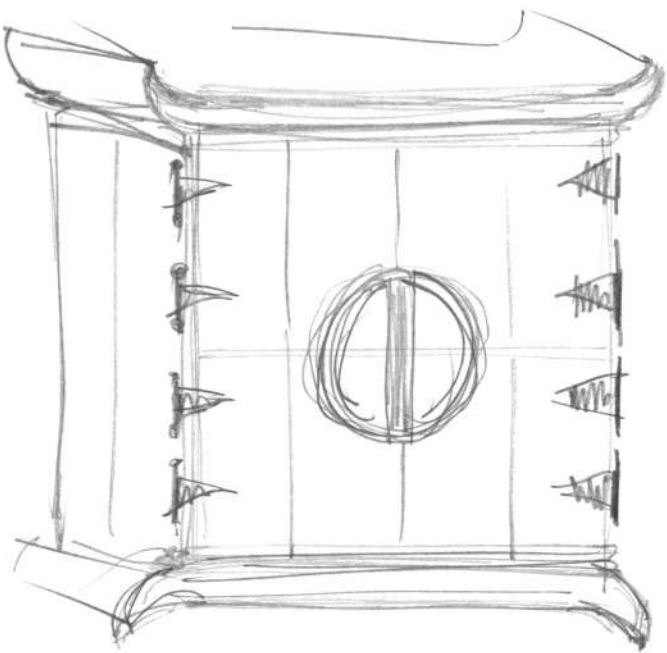

no handle / *
(no visible hinge)
variety
- say wood with
silver or gold
plating or colour
in groove details
= ? possible to have
concealed hinges +
completely fold back
doors - no.



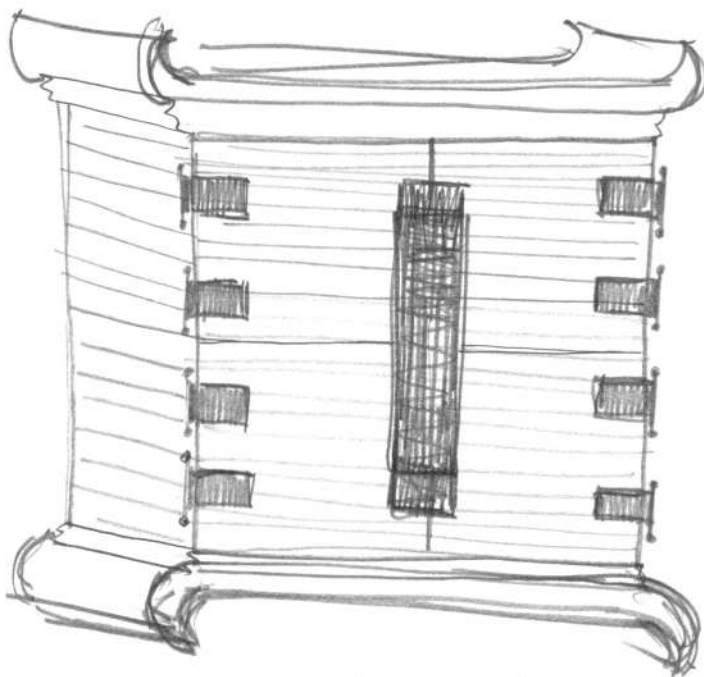
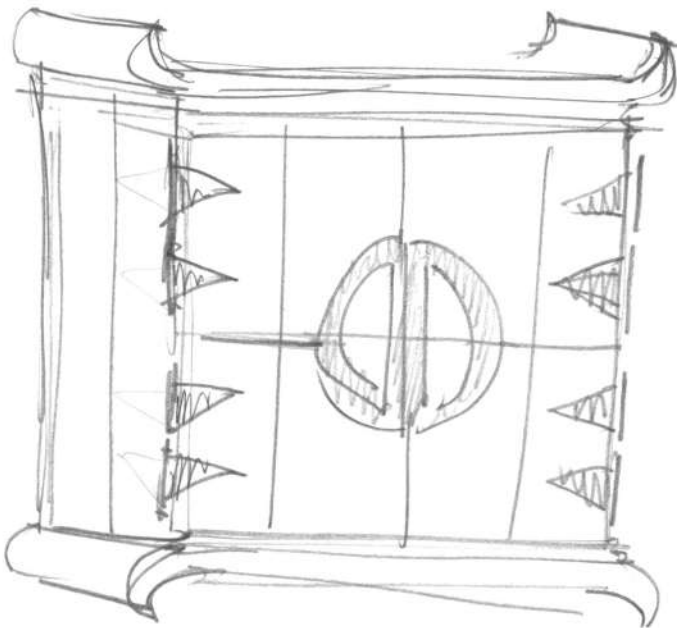

Use as
bar.

metal work
detail of handles
& hinges - more
restrained



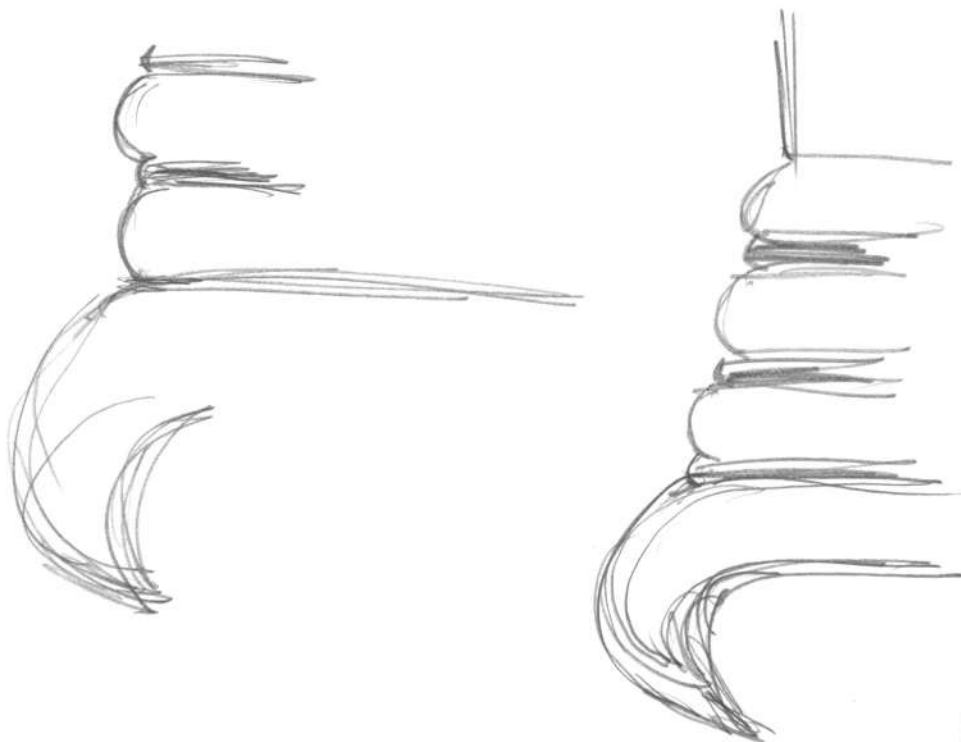
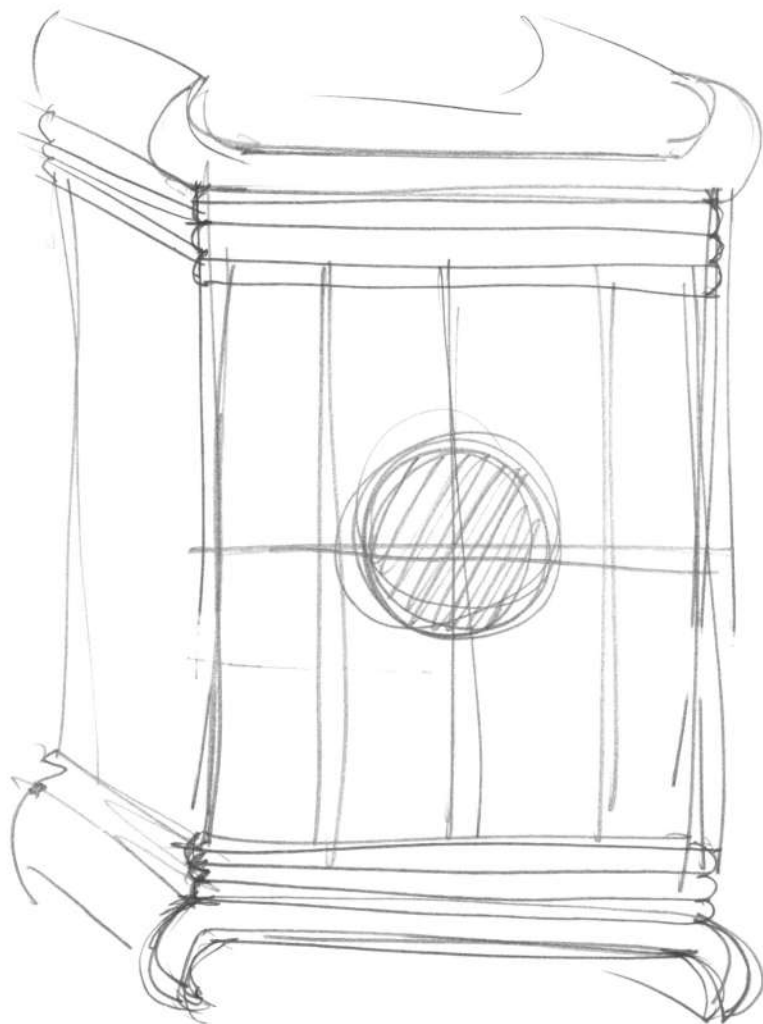

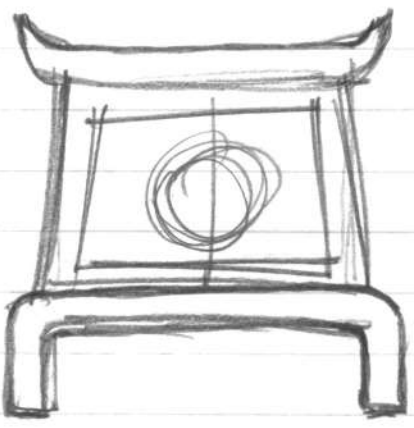
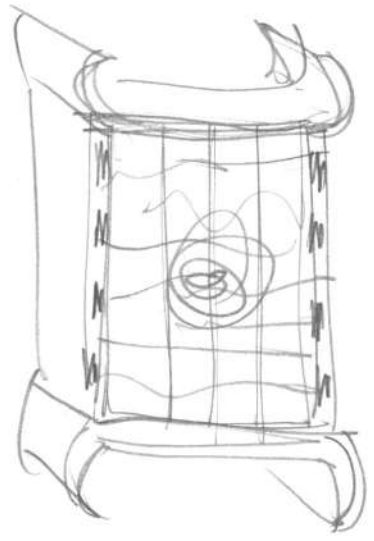
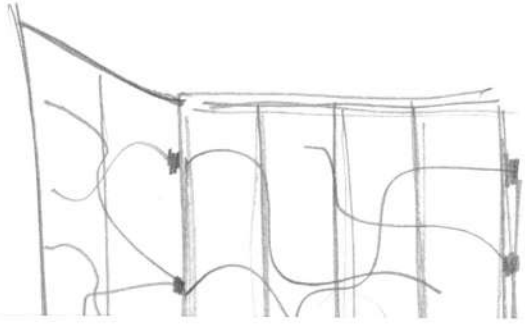

? texture across doors like large scale crackup or lacquer - exp!

4 bar head higher
more "trunka"
if not more make
lower piece.



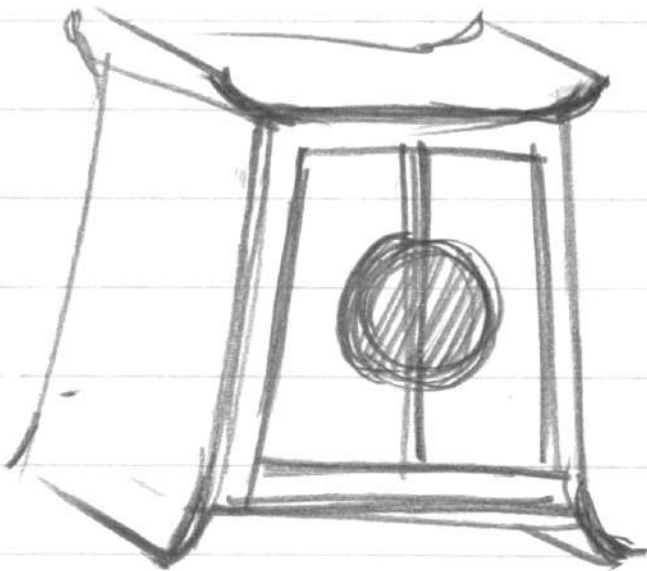
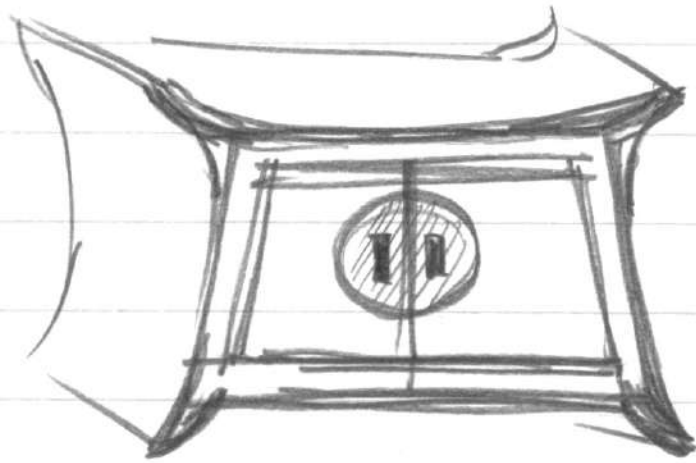

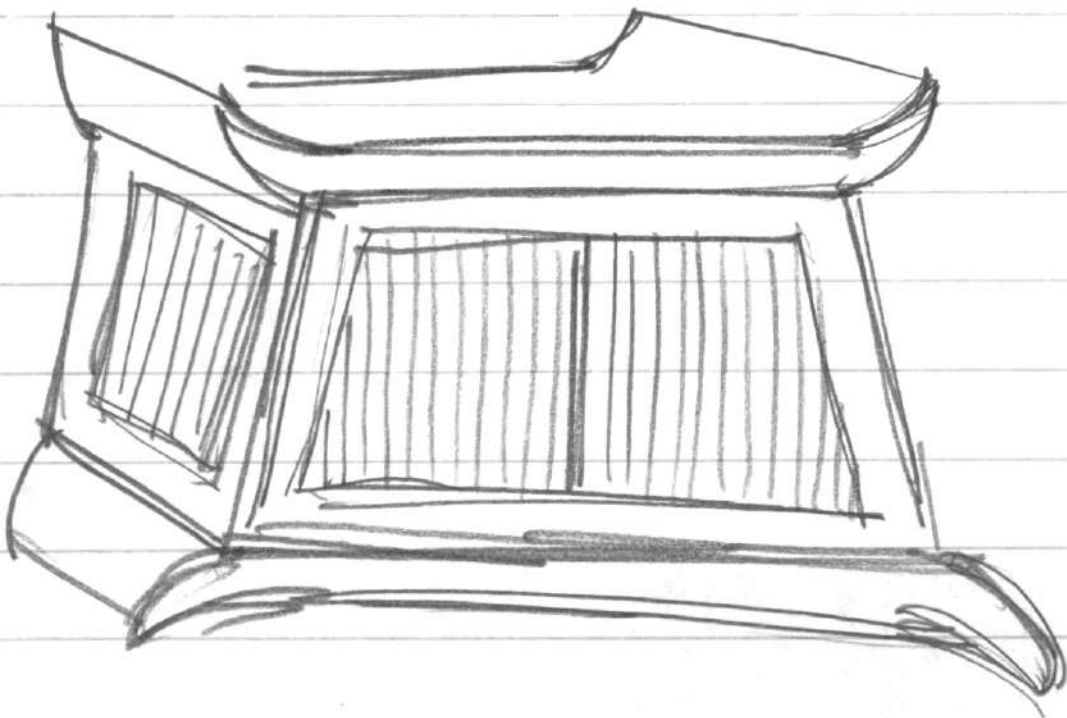
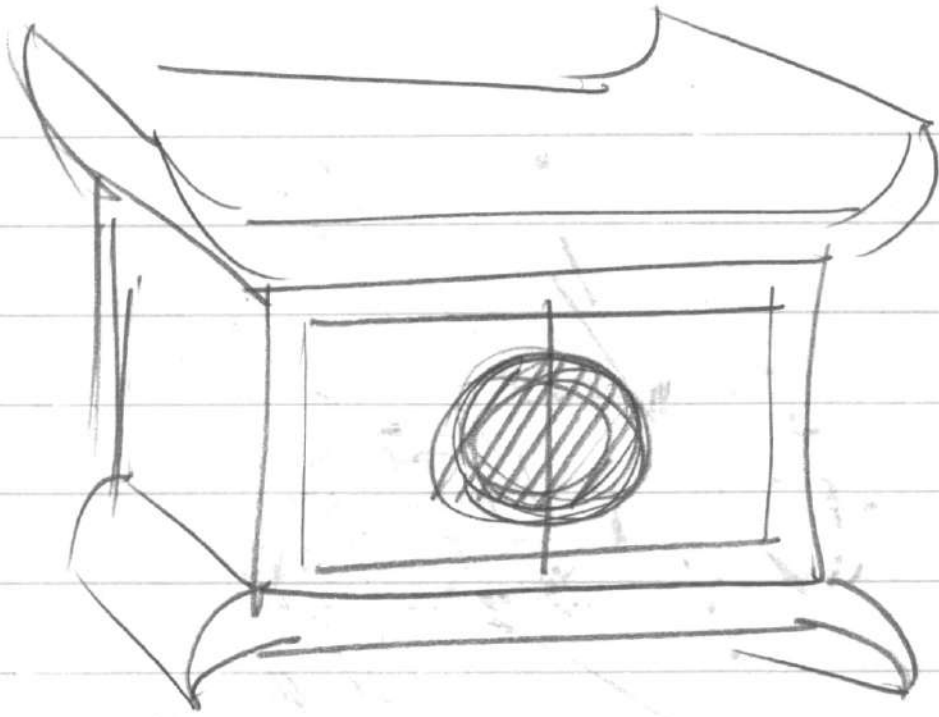

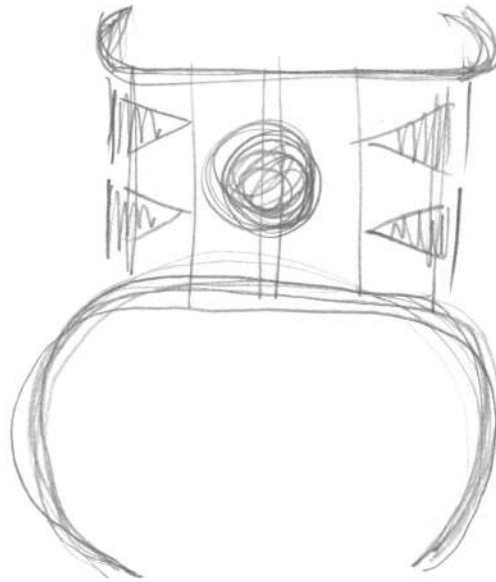

eccentric
variety - v.
Springs/
animal
strong character

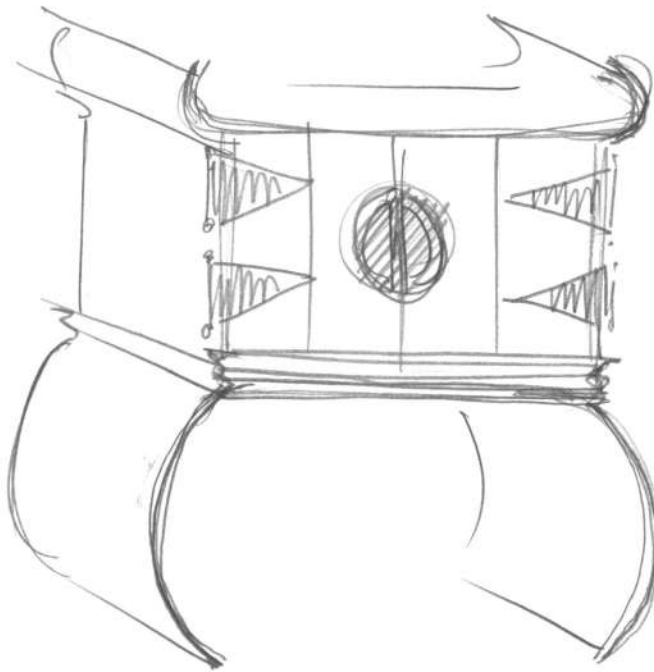

alternative
curve
detail.

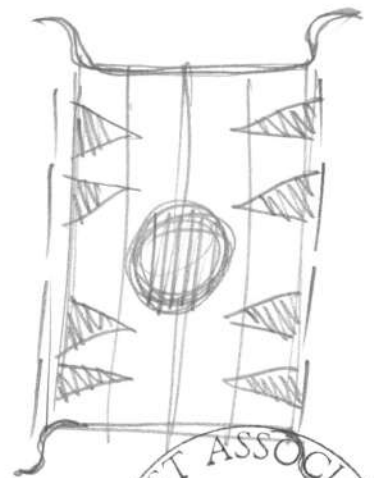
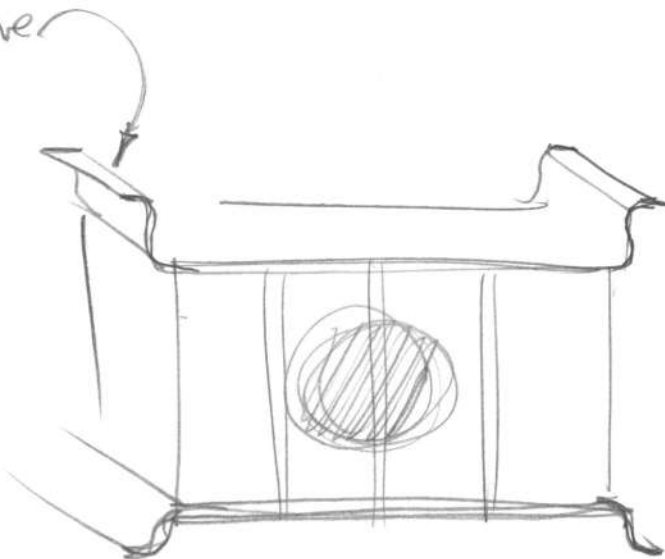

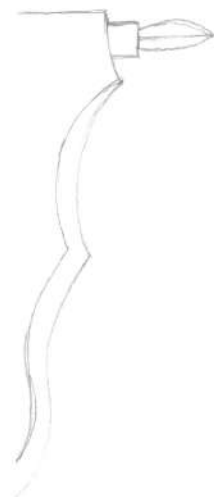

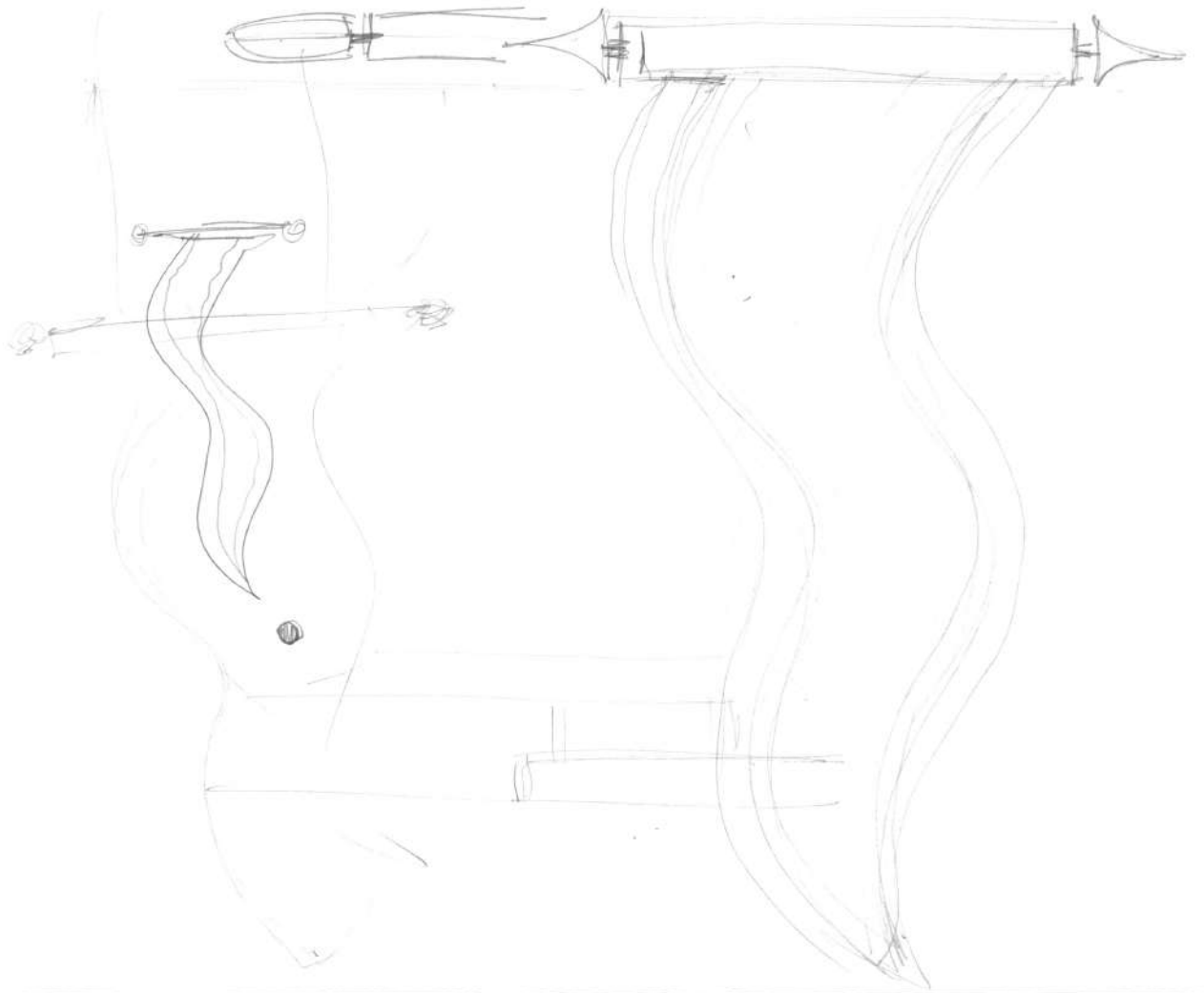

? Details

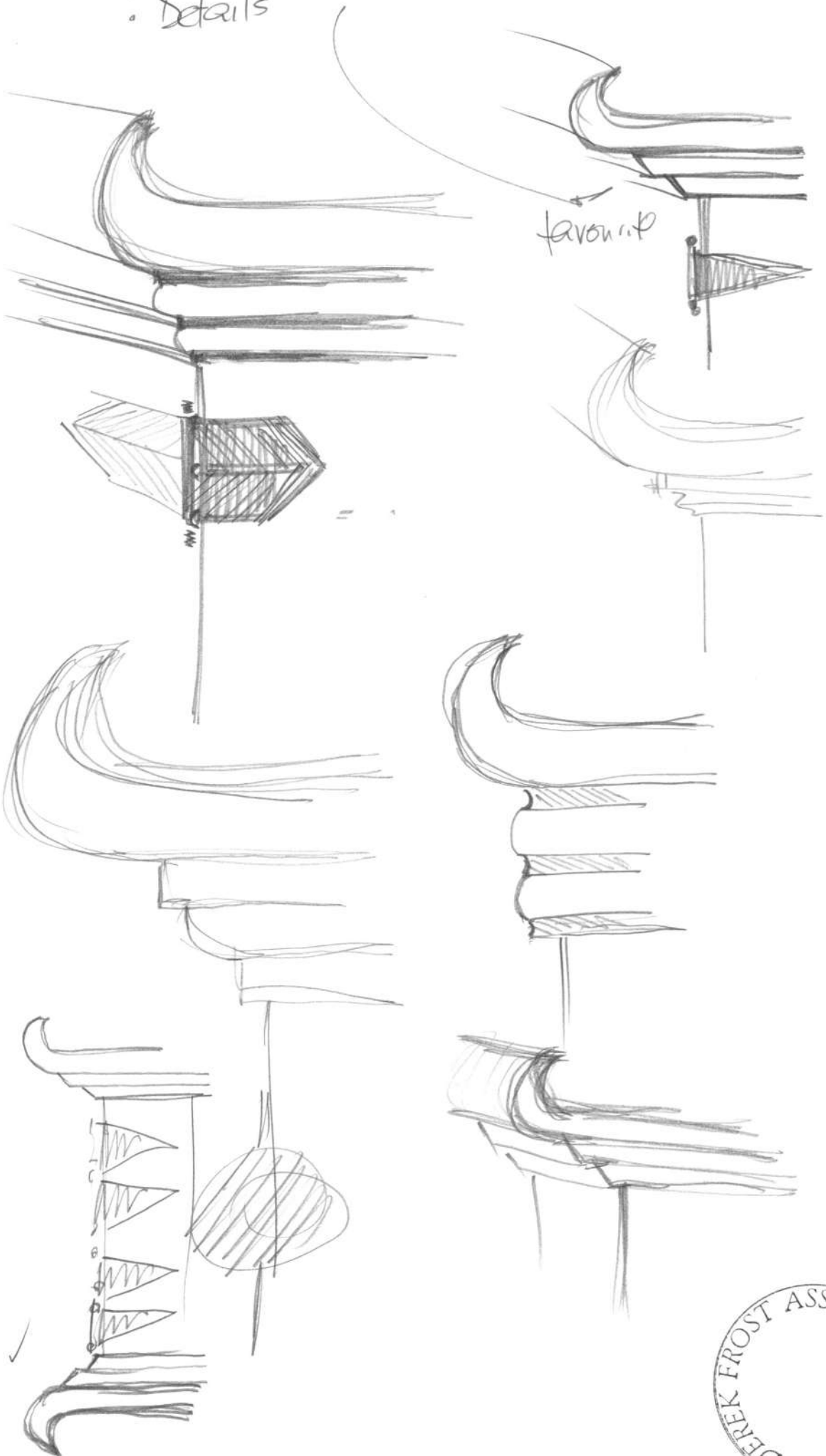

favou...it



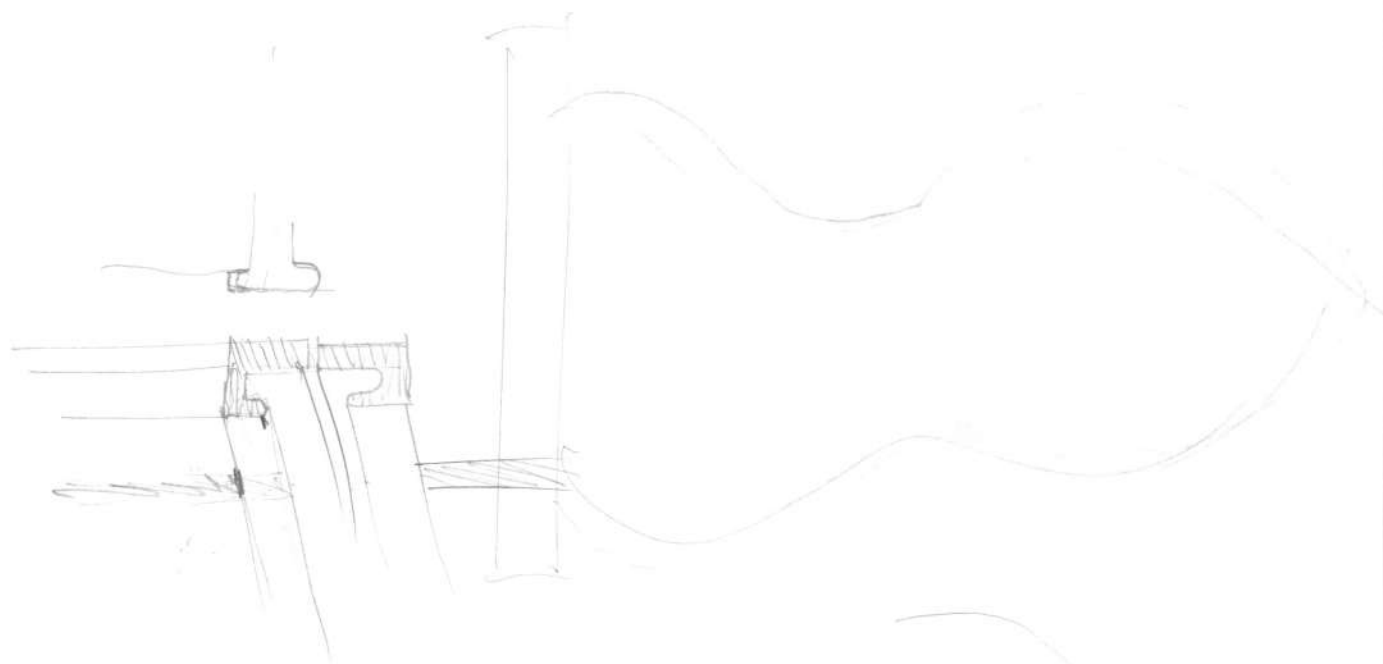

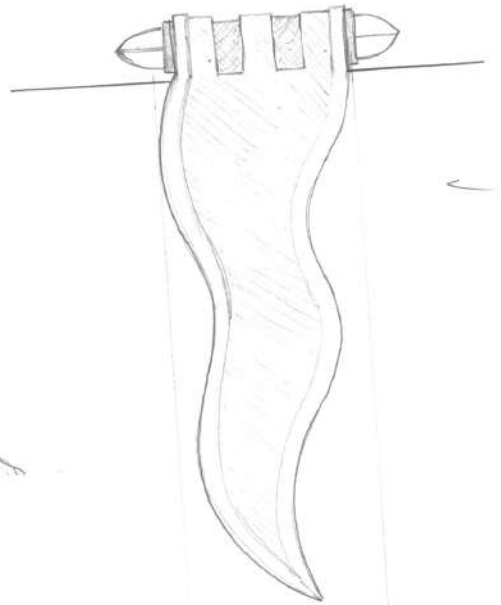

1/2
3/4
1
1 1/4
1 1/2
1 3/4
2
2 1/4
2 1/2
2 3/4
3
3 1/4
3 1/2
3 3/4
4
4 1/4
4 1/2
4 3/4
5
5 1/4
5 1/2
5 3/4
6
6 1/4
6 1/2
6 3/4
7
7 1/4
7 1/2
7 3/4
8
8 1/4
8 1/2
8 3/4
9
9 1/4
9 1/2
9 3/4
10
10 1/4
10 1/2
10 3/4
11
11 1/4
11 1/2
11 3/4
12

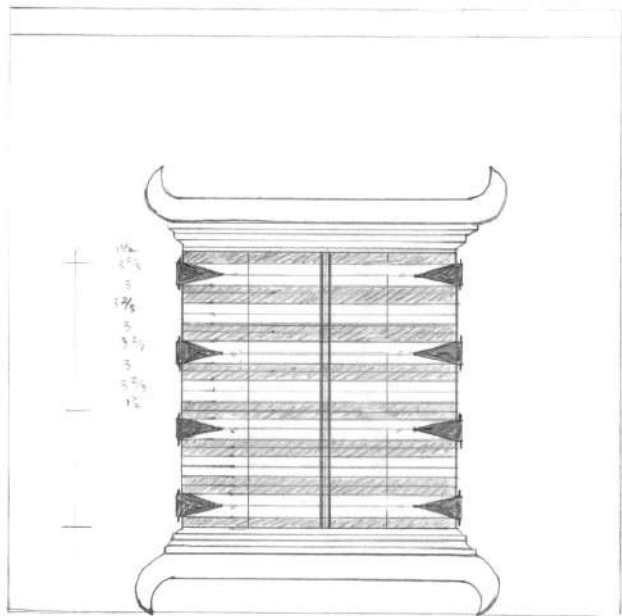
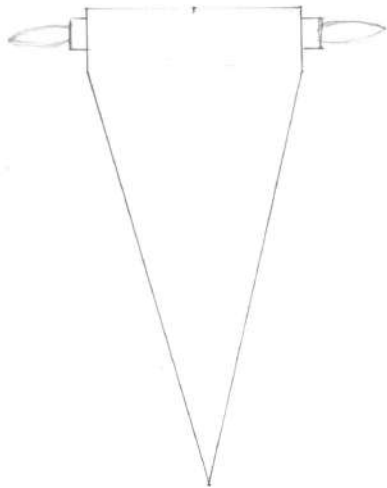

Light Grain



join
(for
book
making)
nothing

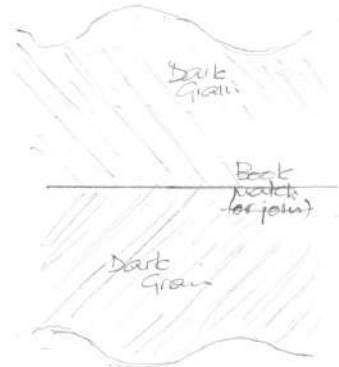

Light Grain

? bookmatches in dark or light?

8A

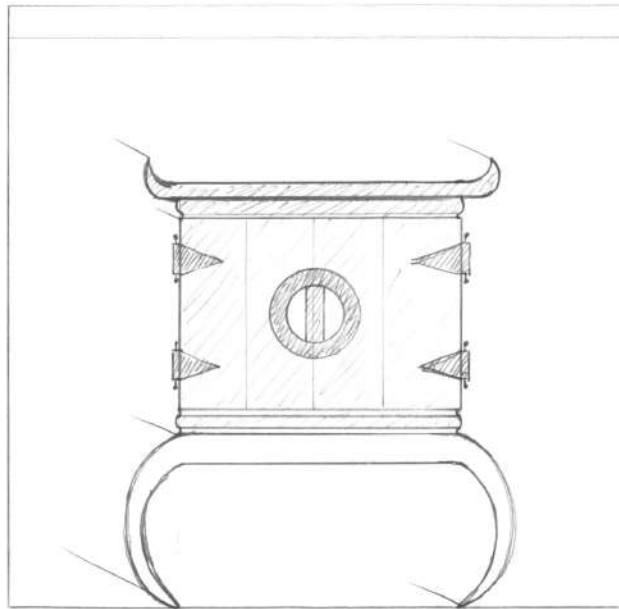
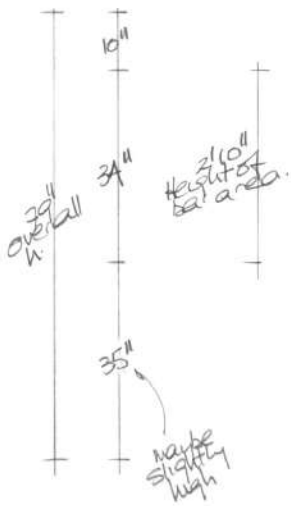

Stronger character/
more bizarre/
slightly animal/
sprung.

Alternative 4.

scale $\frac{1}{2}$ " to 1'0"



7A

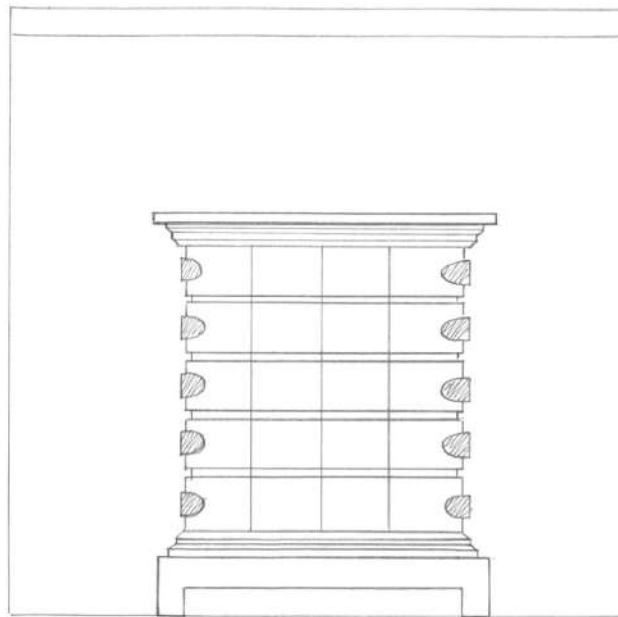

Example showing
bizarre/oriental
character
much reduced
give almost
Georgian/military
feel

- can also
strike a balance
between

Alternative 3.

scale 1/2" to 1'0"



6A

Alternative 2/
doors open

Sketch showing
Cabinet with
bar doors open
and folded back
Store doors under
closed

sculpture/object
displayed over

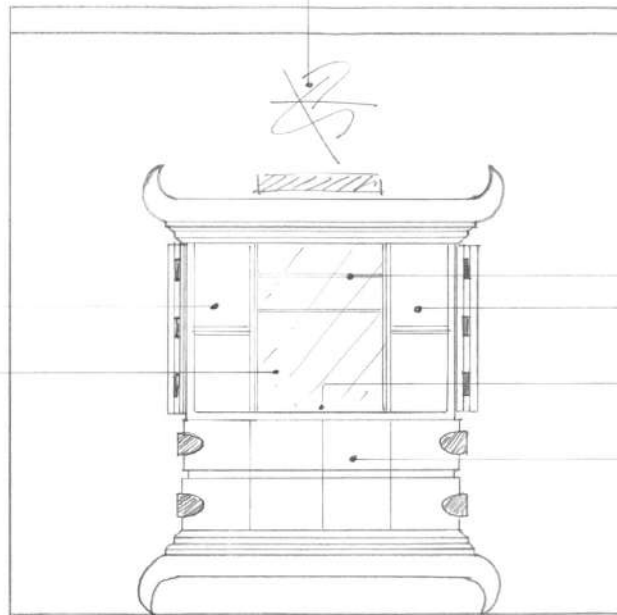

31"
bar height

20"
store

2 level
bottle
store

Mirror
on back

2 glass shelves
for glasses

2 level
bottle
store

work
counter

Storage
under
21" high

scale 1/2" to 1'0"

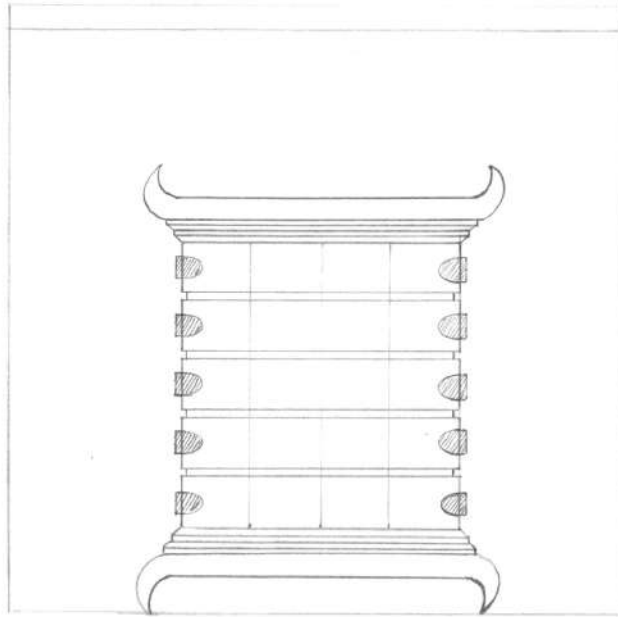
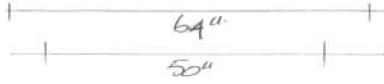
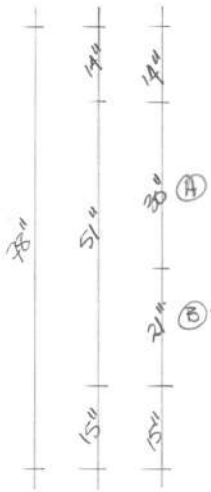

5A

Alternative 2/
doors closed

- (A) separate pair of doors to bar
- (B) separate pair of doors to storage under.

Need tall piece to contrast with credenza or else 2 (no) pieces too similar.

scale 1/2" to 1'0"



4A

Alternative 1
showing bar
door open

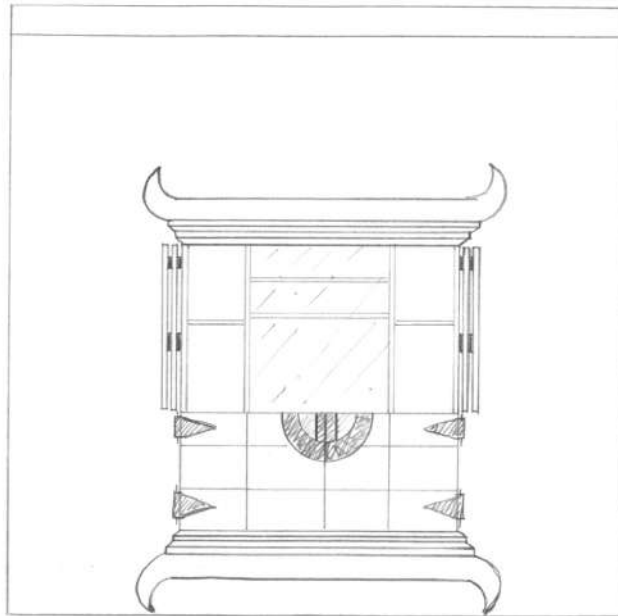

check access
into apartment
re: size

scale 1/2" to 1'0"

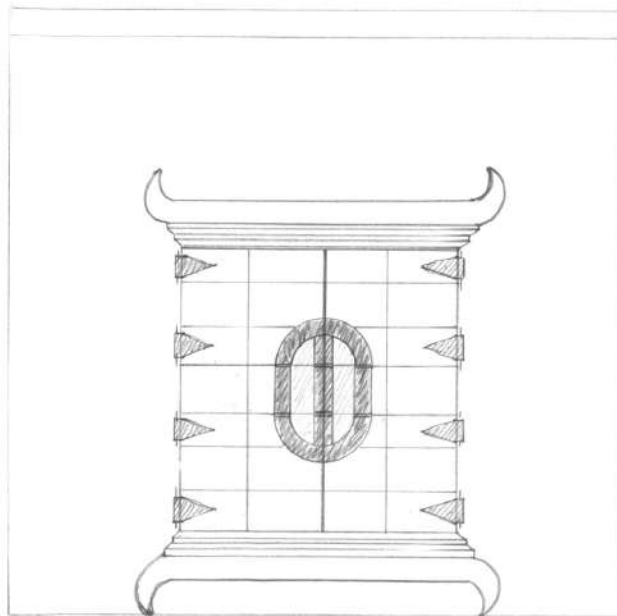

Detail alternative showing clever method to contrive over face + centered handle but bar height + space bigger than cupboard/store below.

Alternative 1 doors closed.

? overall depth + finish

scale 1/2" to 1'0"



2A.

67"

have my bar 67" (mine 73") wide to equal 2 other panels with slatted handle

Equal 24"

Equal 24"

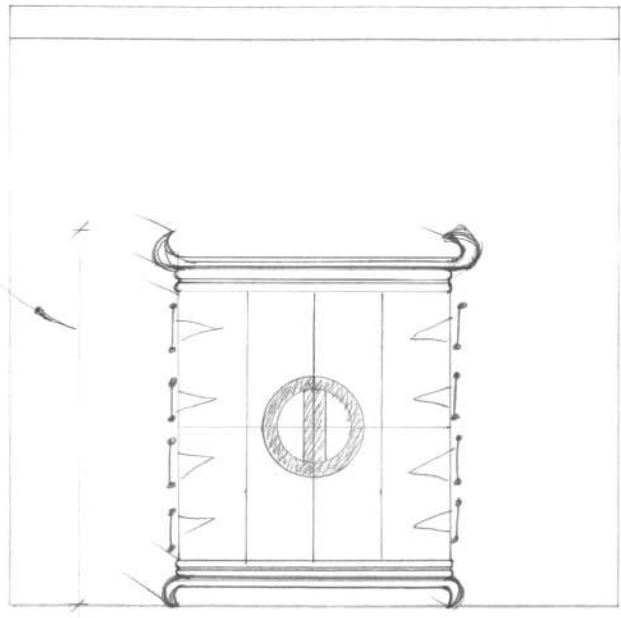

Folter/Quater.

Height with upper bar
24" - less than other alternatives but has additional strape under.

Scale 1/2" to 1'0"



BW

Trimble

Dining Table

London

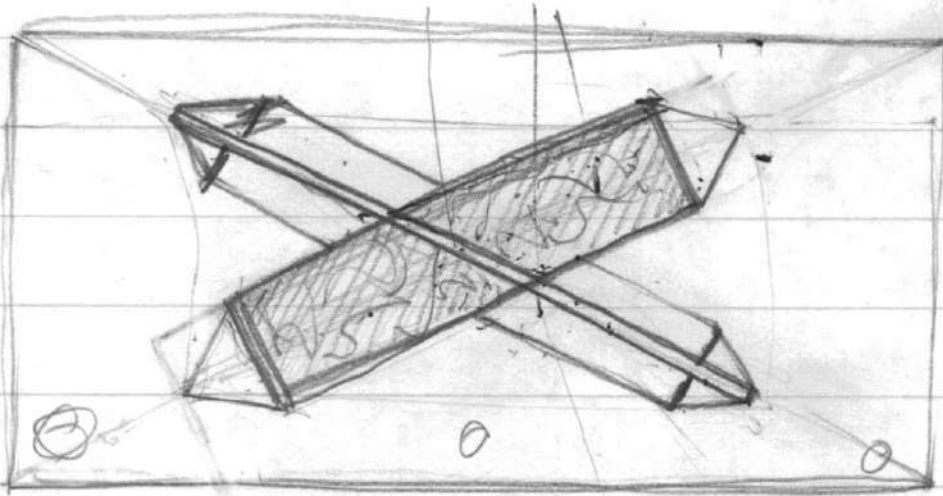

Wood
viewer

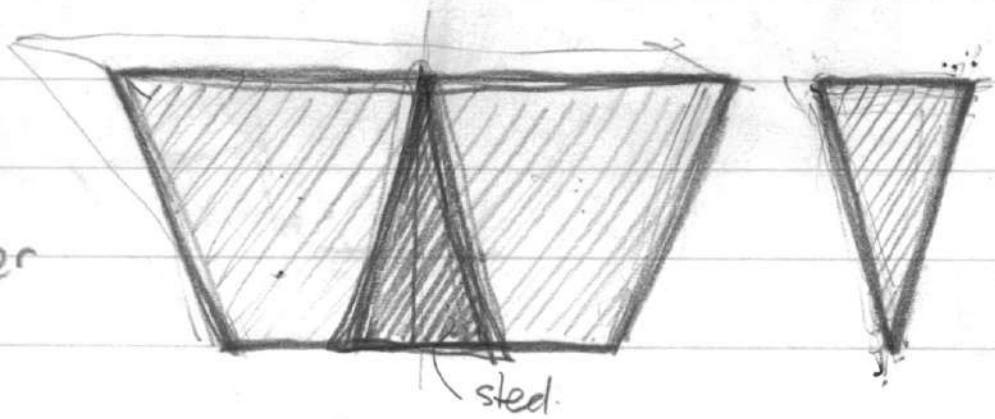

polished
S.S.

Wood
viewer

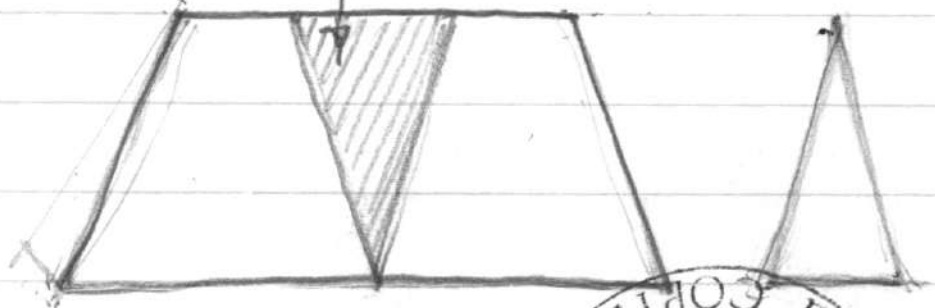



ST / PH.

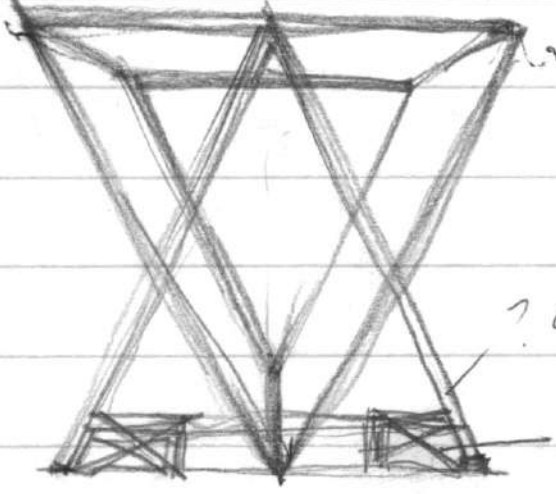

? gusset steel

timber frame
wk.

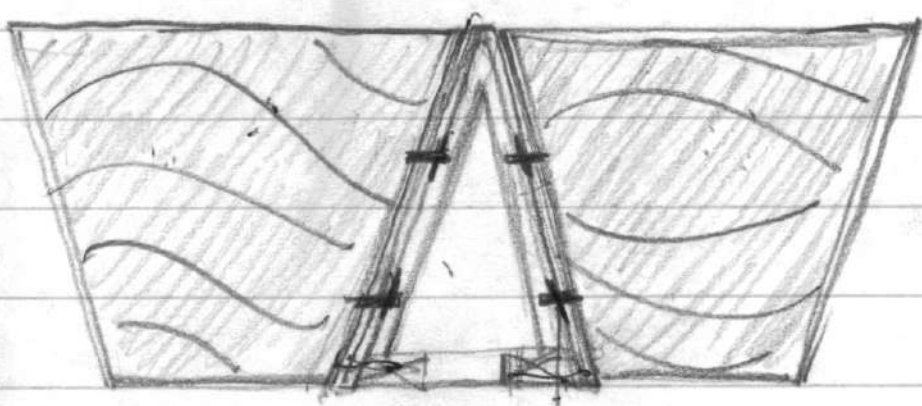

locating
pins (4 or 6?)
- 2 horiz at top
1 at base

2.500 x 1.300
table top

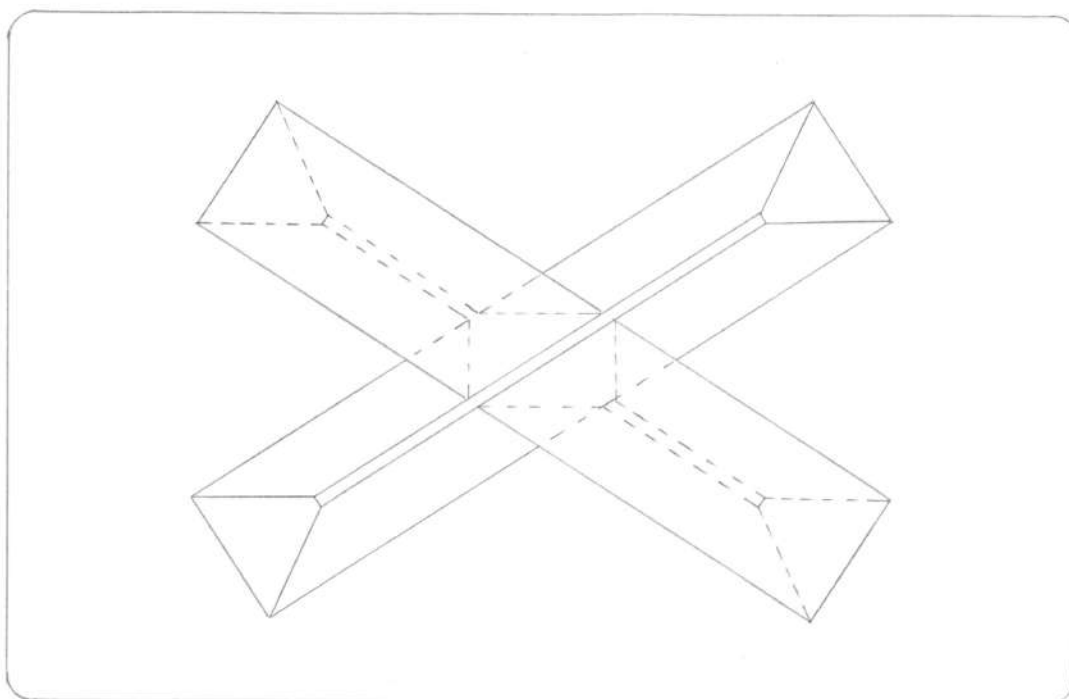

Plan - superceded base profiles.

Sketch proposal dining table for Simon + Paul
Scale 1:10
date Feb '87.

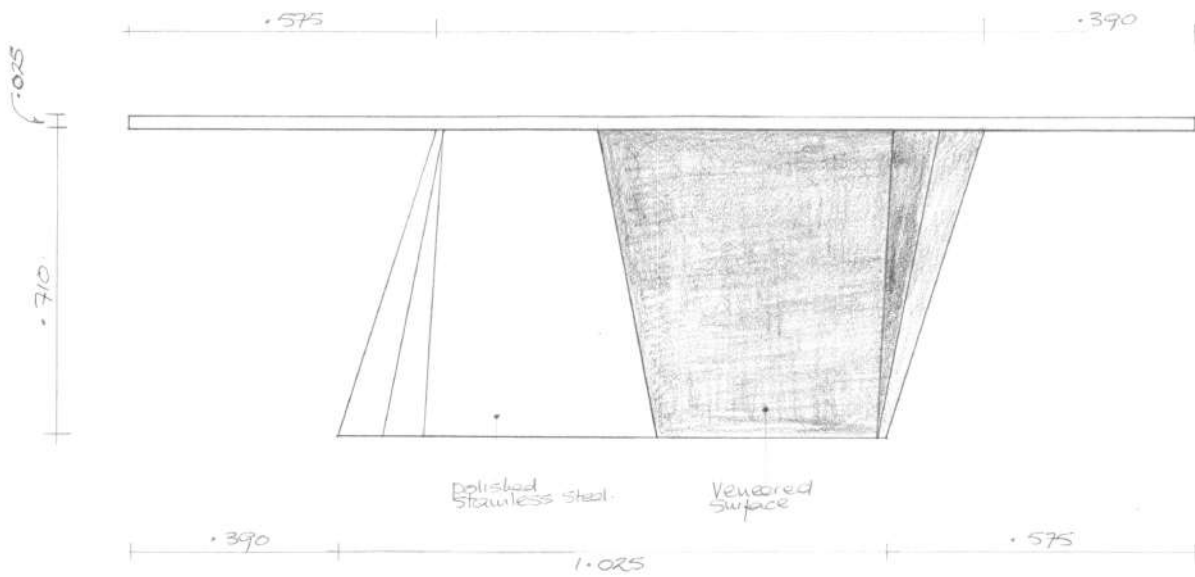

SIDE ELEVATION

Overall height = 0.735 m.

Sketch proposed dining
table for Simon + Paul
date Feb '87
scale 1:10.

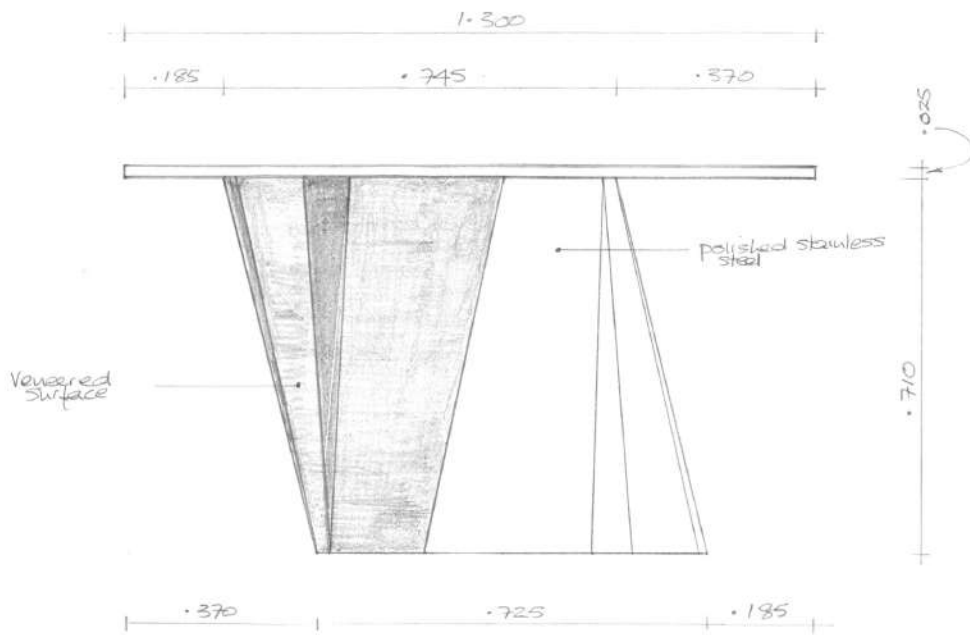

SIDE ELEVATION
overall height = 0.735 m

Sketch proposal dining
table for Simon + Paul

date Feb '87
scale 1:10

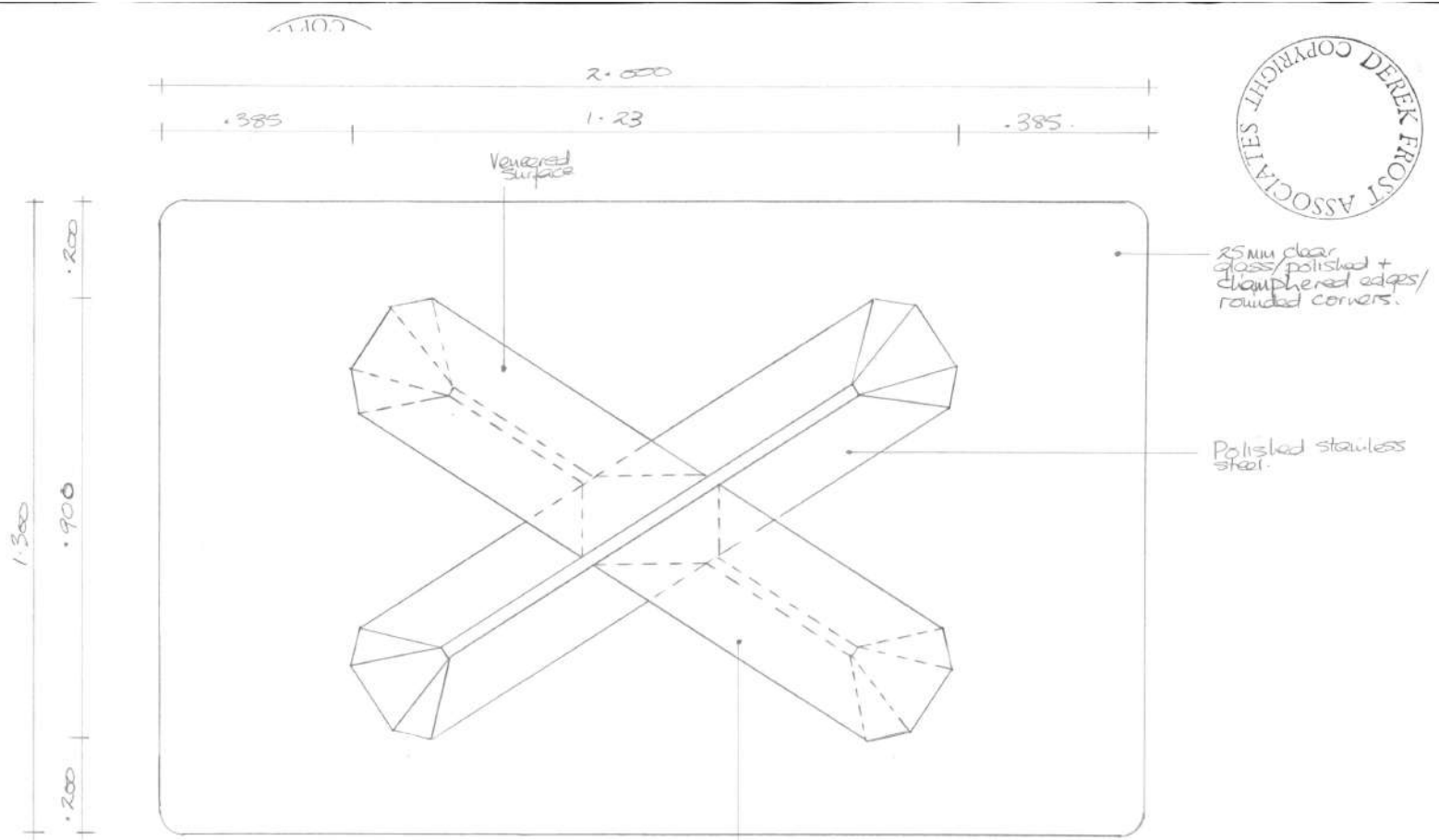

PRAN.

Sketch proposed dining table for Simon + Paul date Feb '87 scale 1:10.



BY

Sassoon

Classical Desk

London

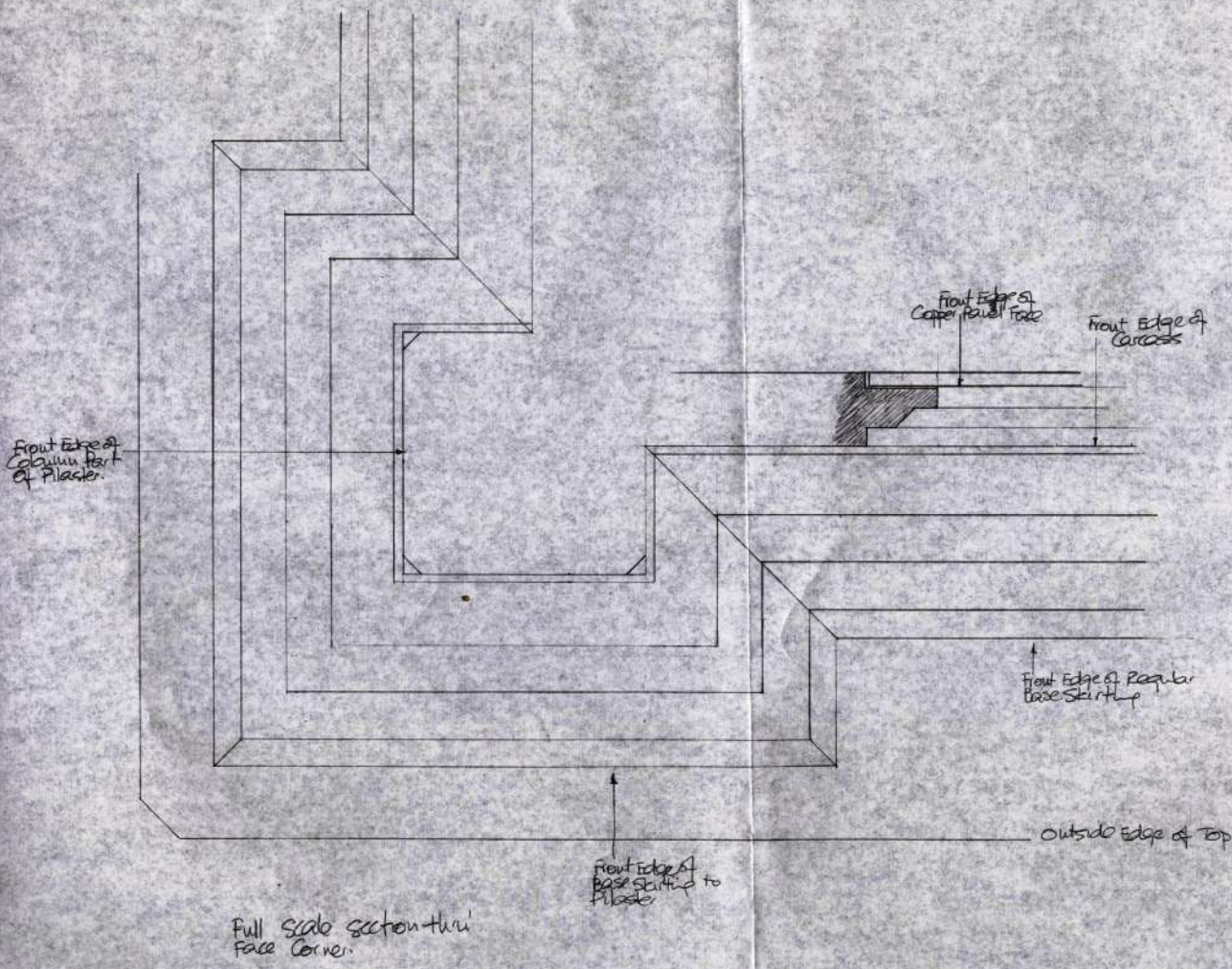

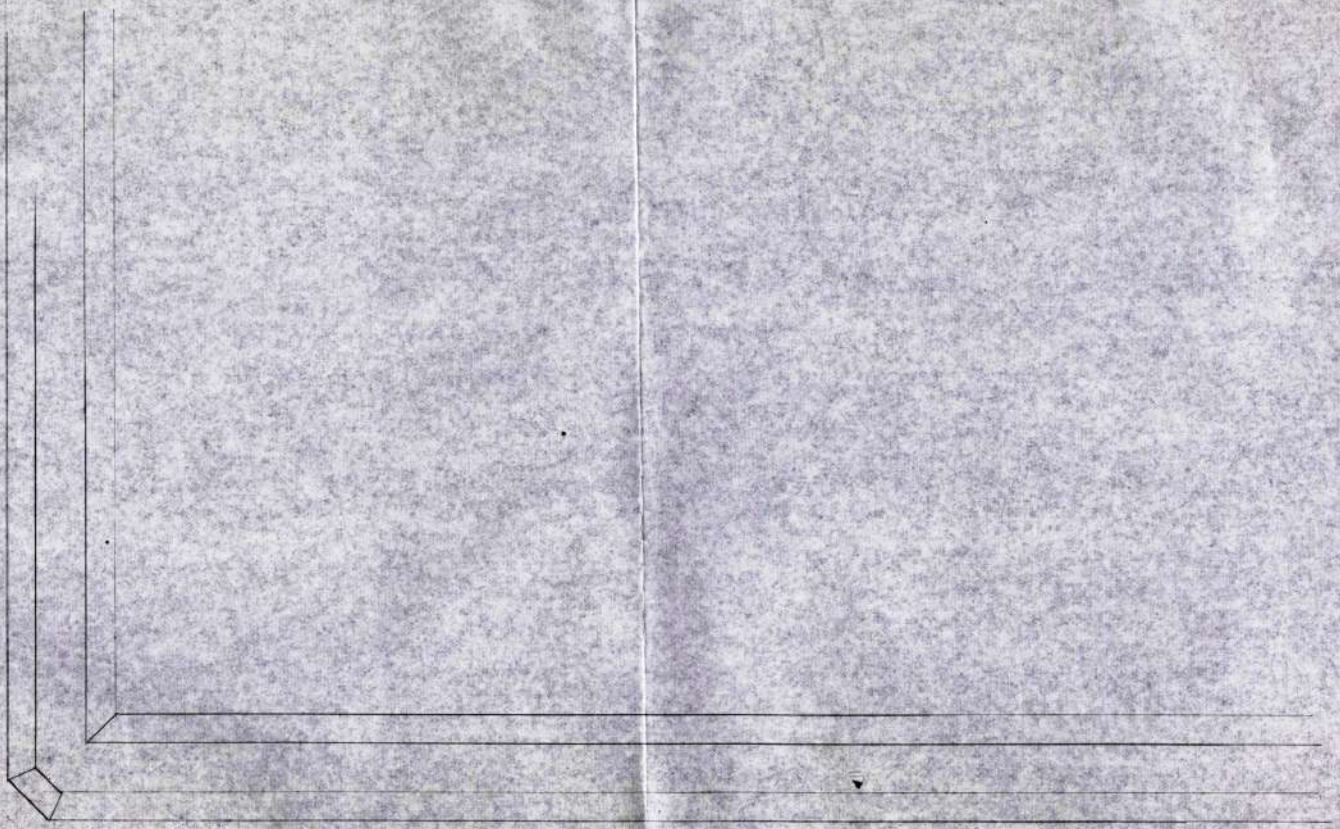

Full scale detail - Plan of Top / Corner detail

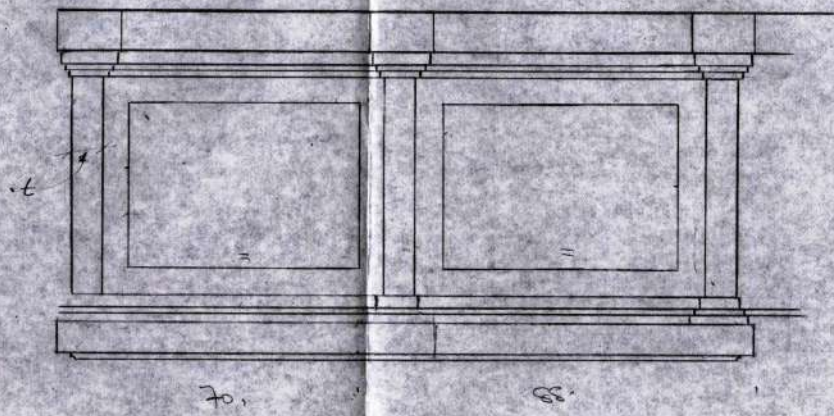

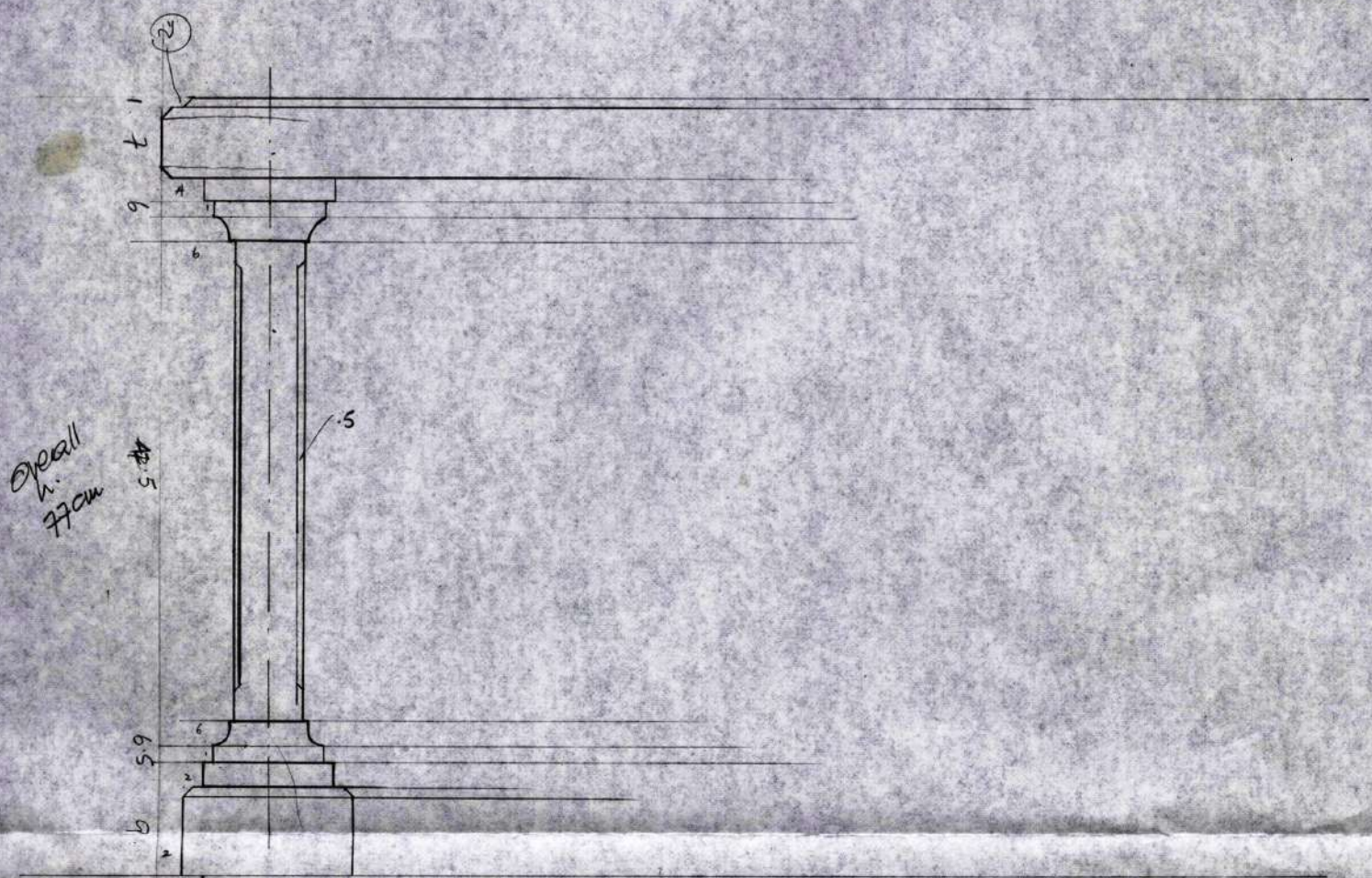

Scale 1:5

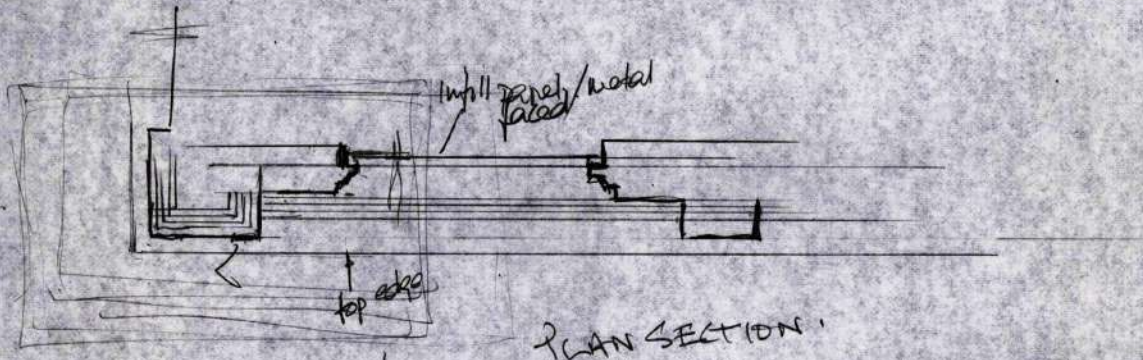

PLAN SECTION
 regular

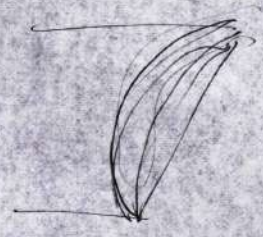
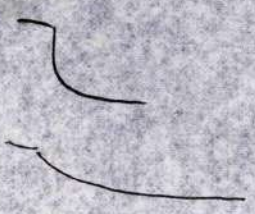
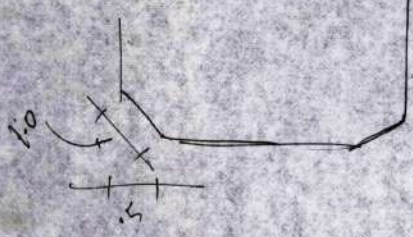

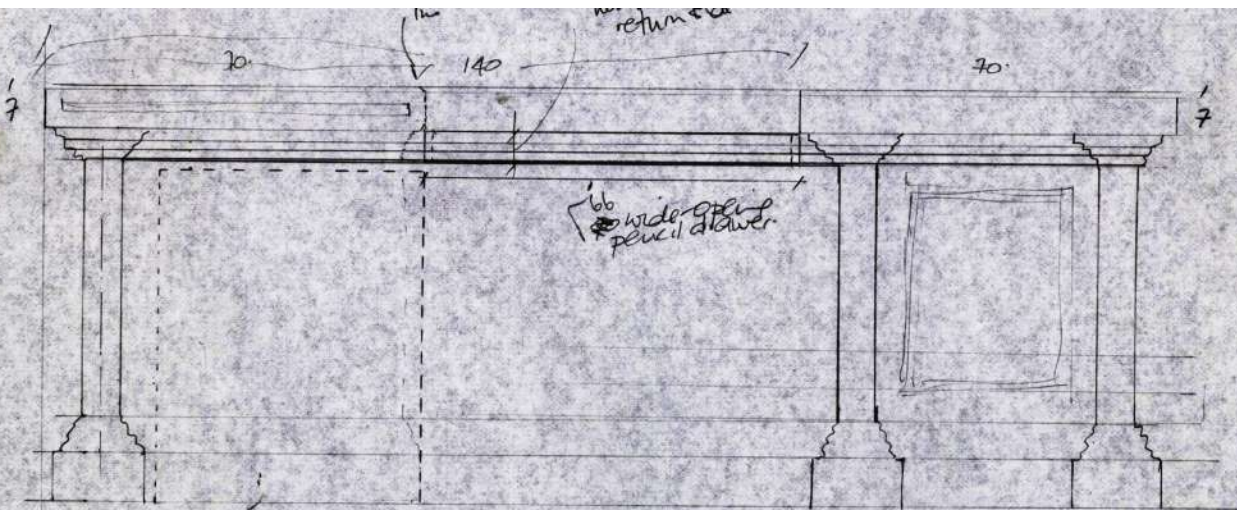

Free standing
flip cabinet
62cm high x 49
cm wide

As Flip Cabinets
are 71h.
elsewhere
- ? use

Elevation
↓

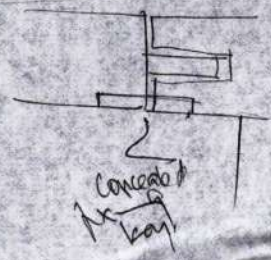

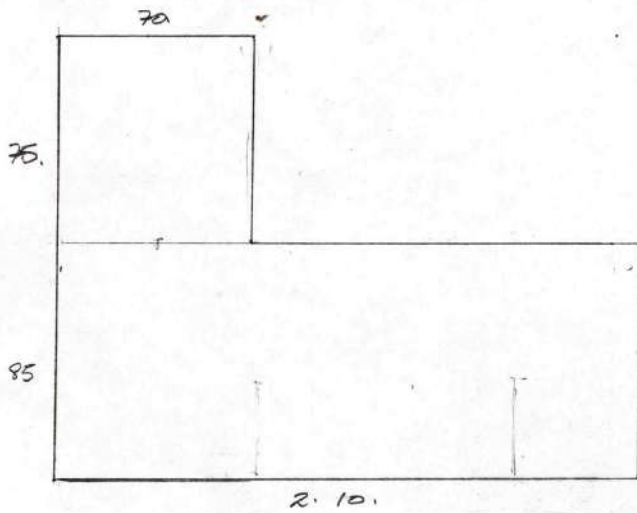

discussed size

best AS.
1:20 Aug '87

45.6 20.17 6 22 6 20.17 6.45

Superic

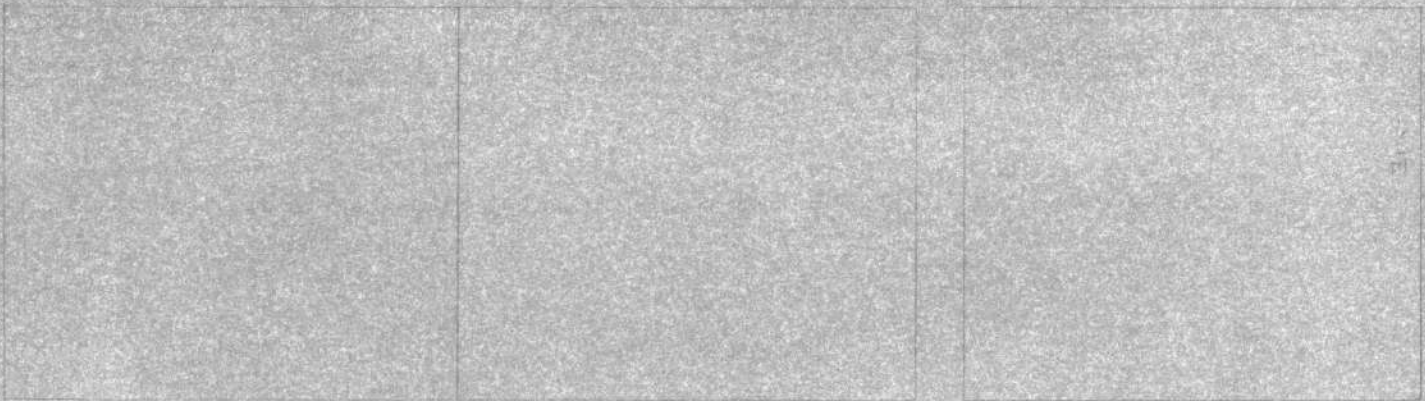
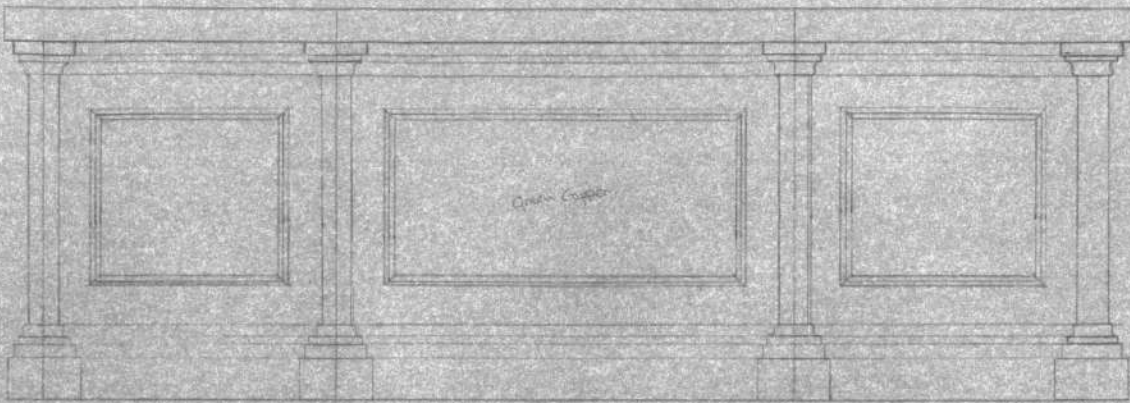

24/17

24/17

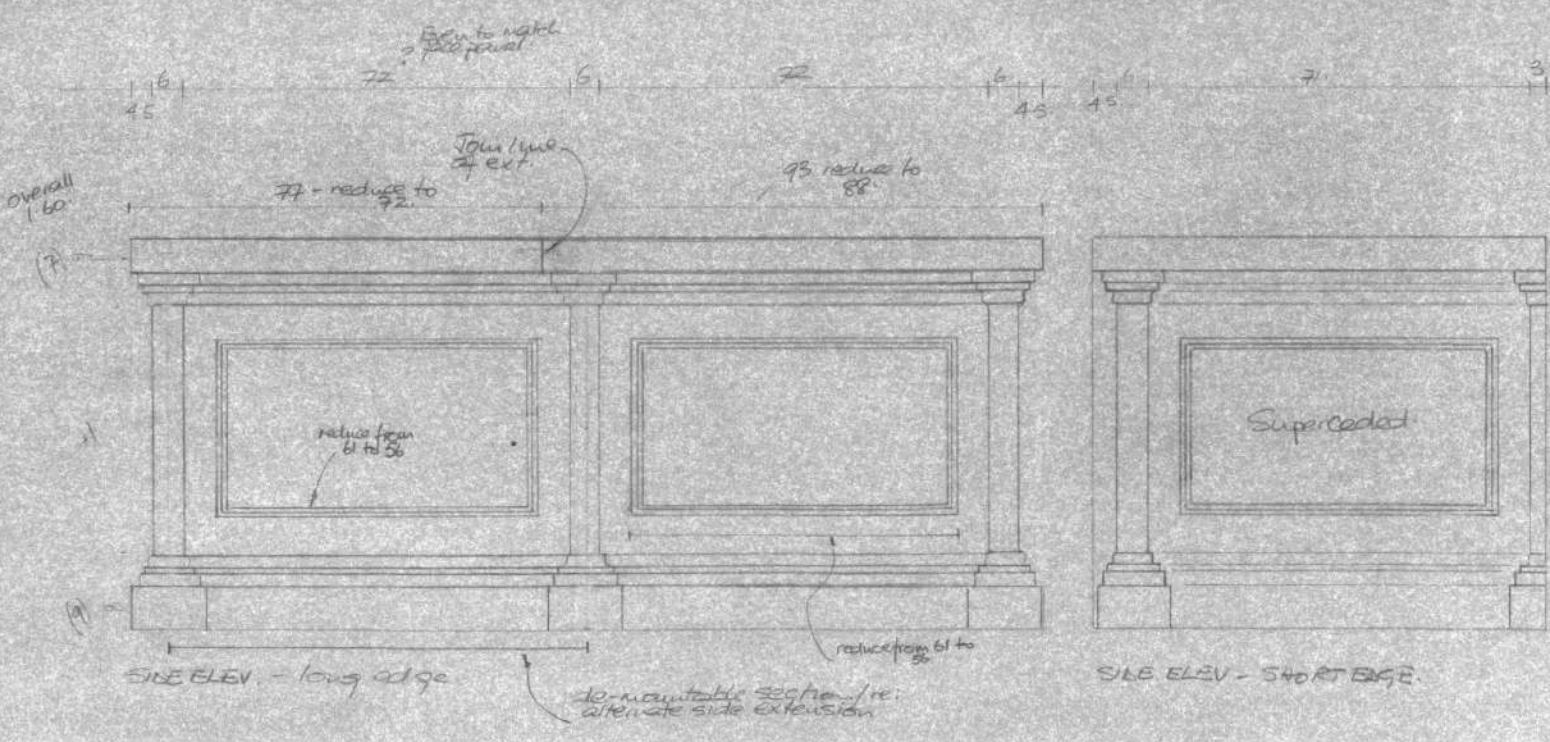

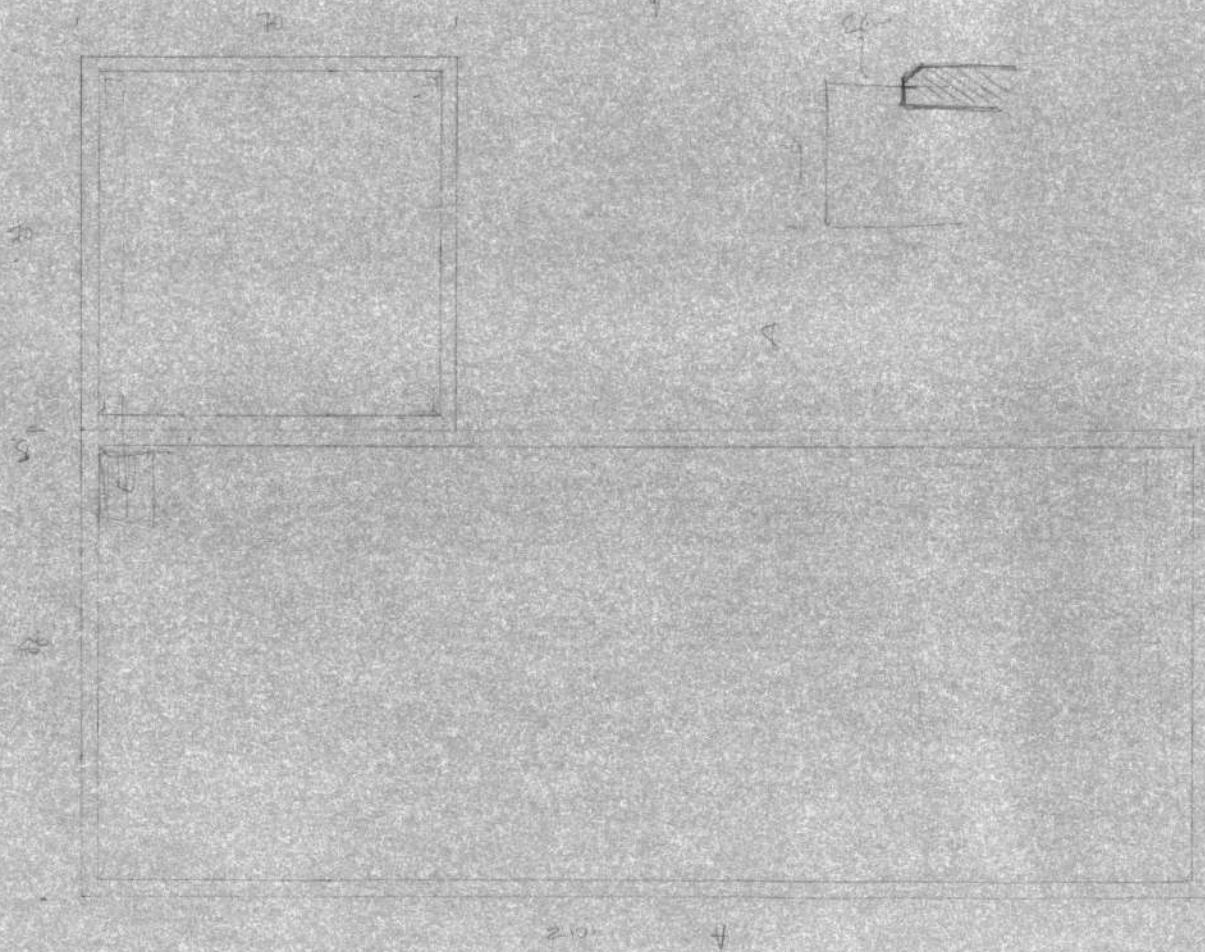

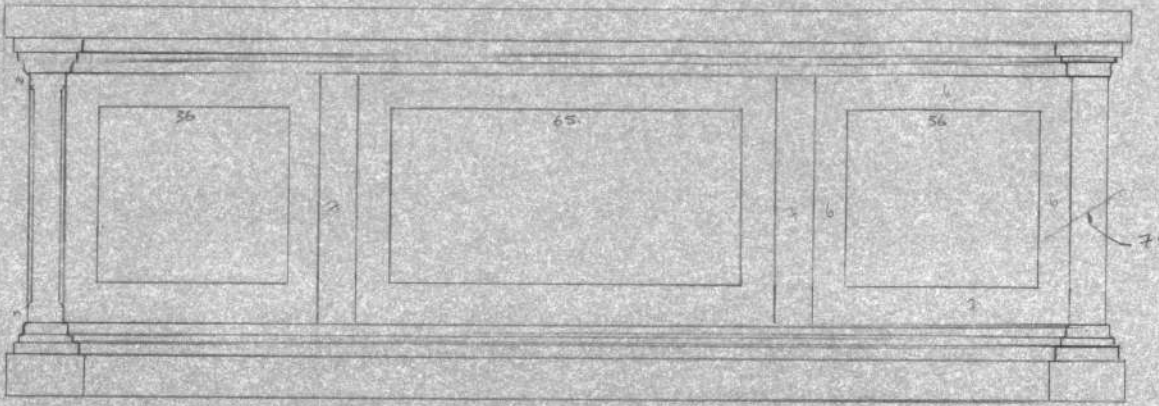

AS DSK
Revised Front Elev
- inside pilaster

1.10
Aug '87

make 7h overall
H to inside
drawer 6l

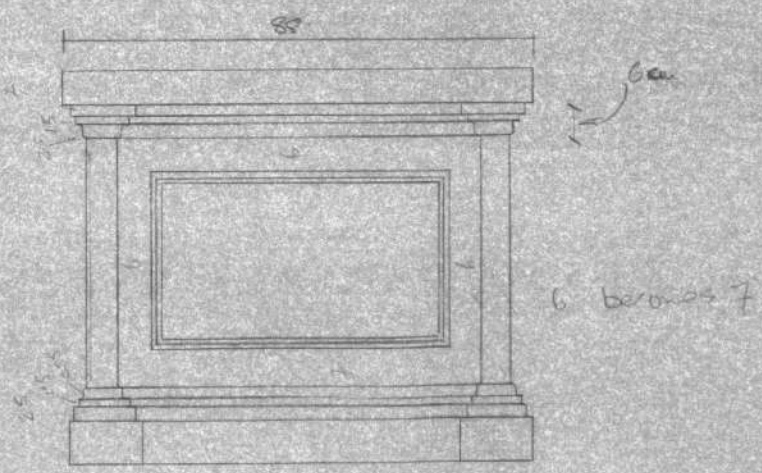

End Elevation

As desk
Revised Long Side Elev
- wider pilaster

Superior

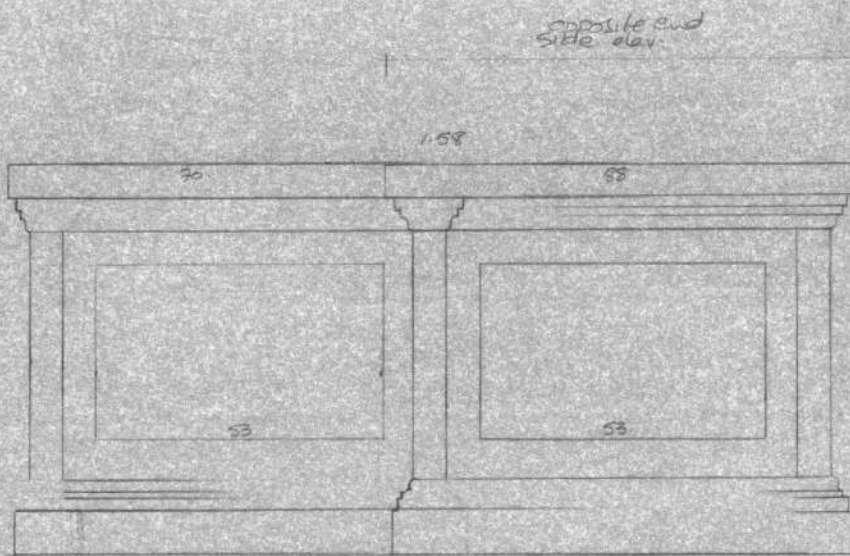



BZ

Designer

Oyster Table & Chairs

Hampshire, UK

New Table
N'ore

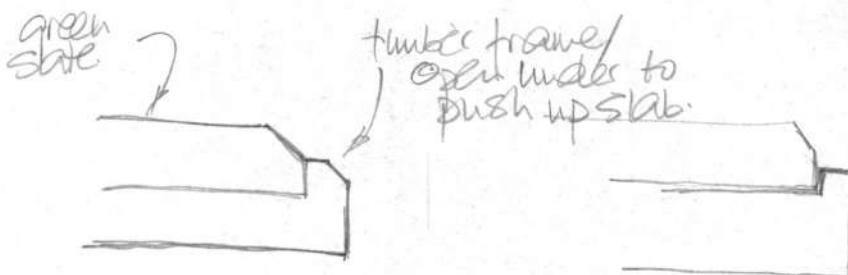
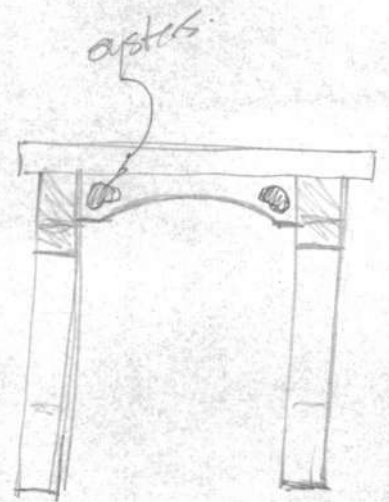
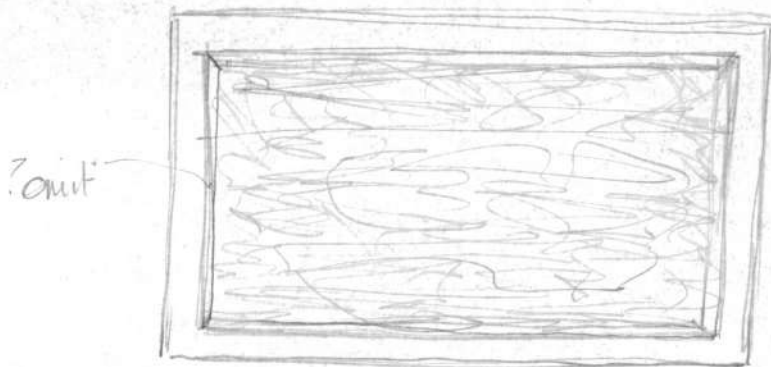
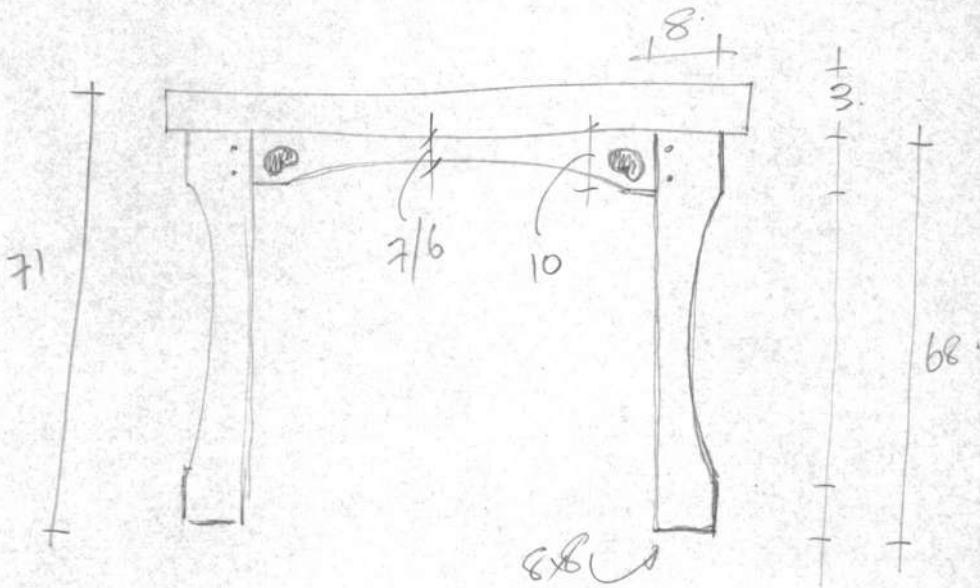
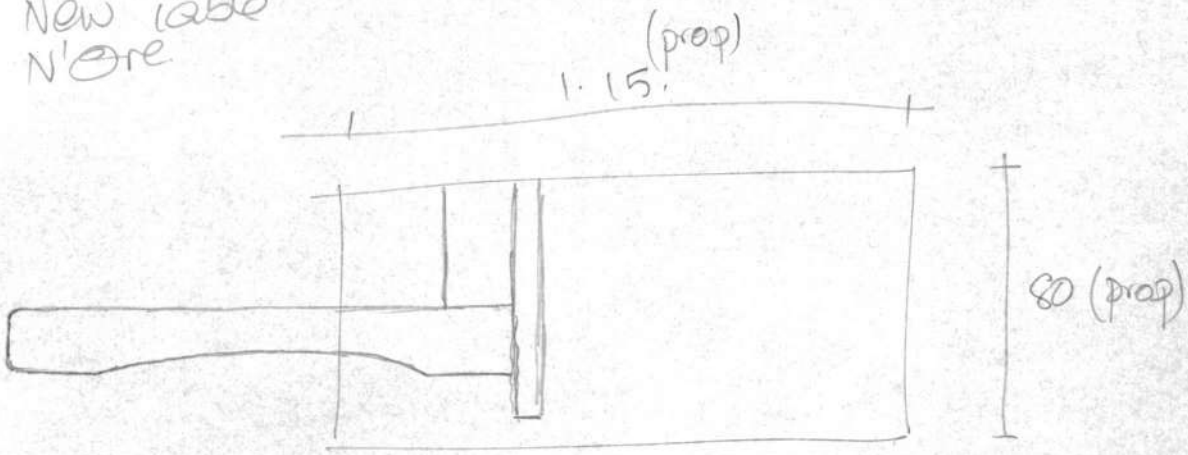

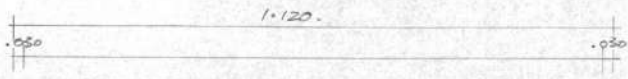

green slate.

TABLE FOR NEEDSORE.

scale 1:10
date NOV '88.

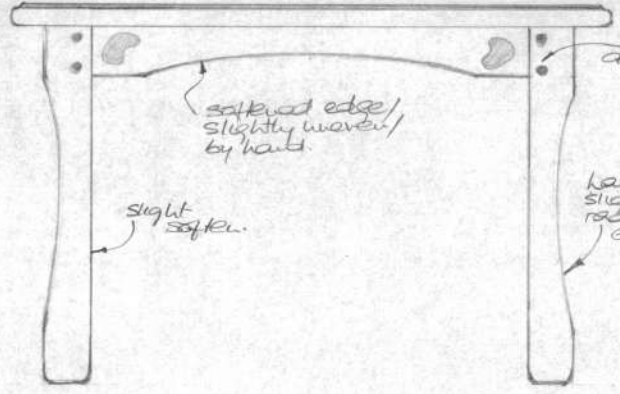
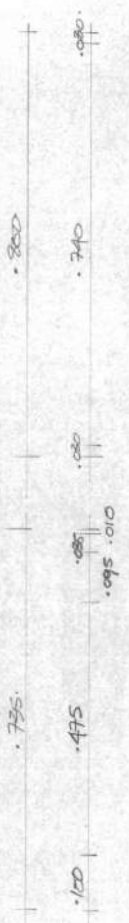

LONGSIDE ELEVATION/PLAN OVER

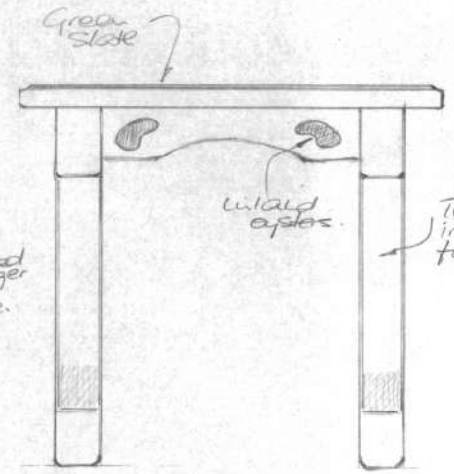
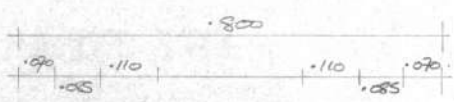

SHORTSIDE ELEVATION

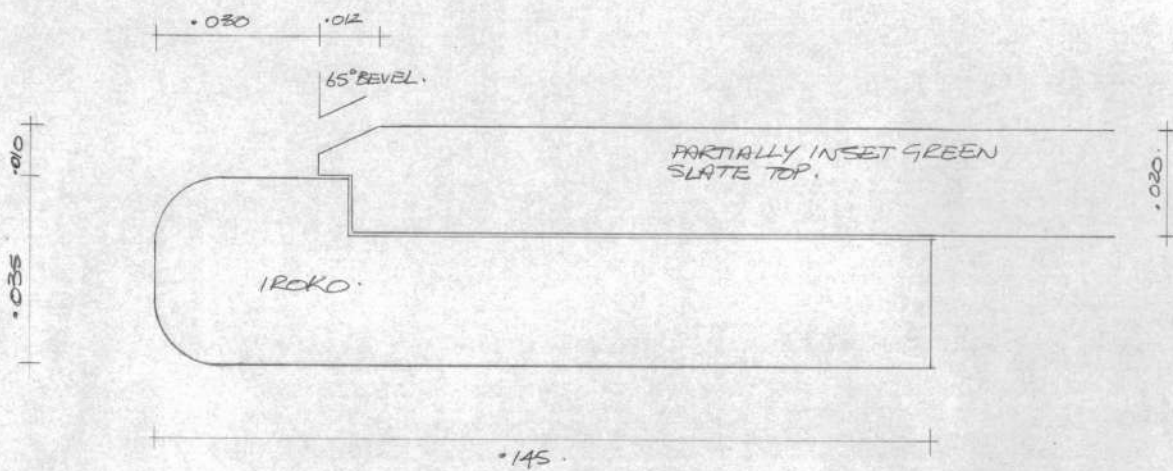

FULL SCALE SECTION THRU' TOP

(Showing bevelled/inset detail slate to oak plus profile detail oak edge)

1 ROCK TO BE HAND SOFTENED AND TEXTURED TO MATCH EXISTING OYSTER CHAIRS.

TABLE, NEEDSORE

full scale
date: Nov '88.

1.120
 .030 .030



Green Slate top.

TABLE FOR NEEDSCORE

Scale 1:10
 date NOV '89.

HAND SOFTENED AND
 TEXTURED IROKO TO
 MATCH OYSTER CHAIRS

.800
 .740
 .030

.070 .110 .110 .070
 .085 .085

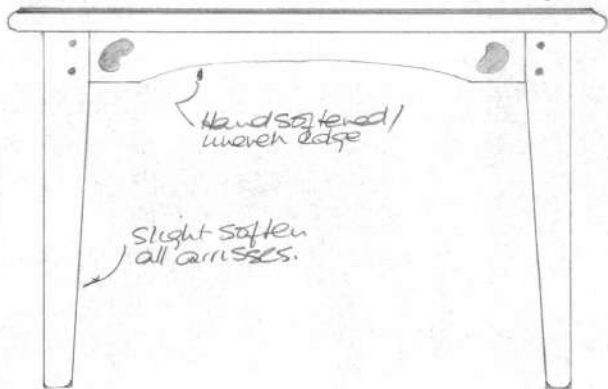

Handsoftened/
 wavesh edge

Slight soften
 all armrests.

.800
 .070 .110 .110 .070
 .085 .085

dowels

sew w/ set
 slate top.

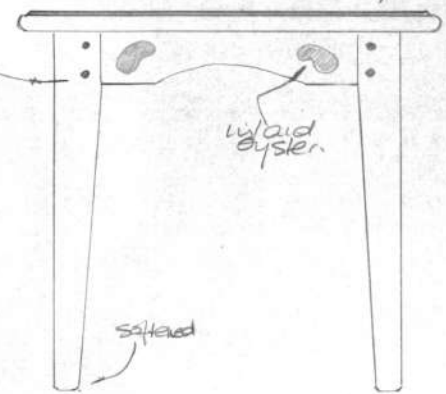

laid oyster.

softened

5cm

LONGSIDE ELEVATION / PLAN OVER

SHORTSIDE ELEVATION

.735

.085 .010

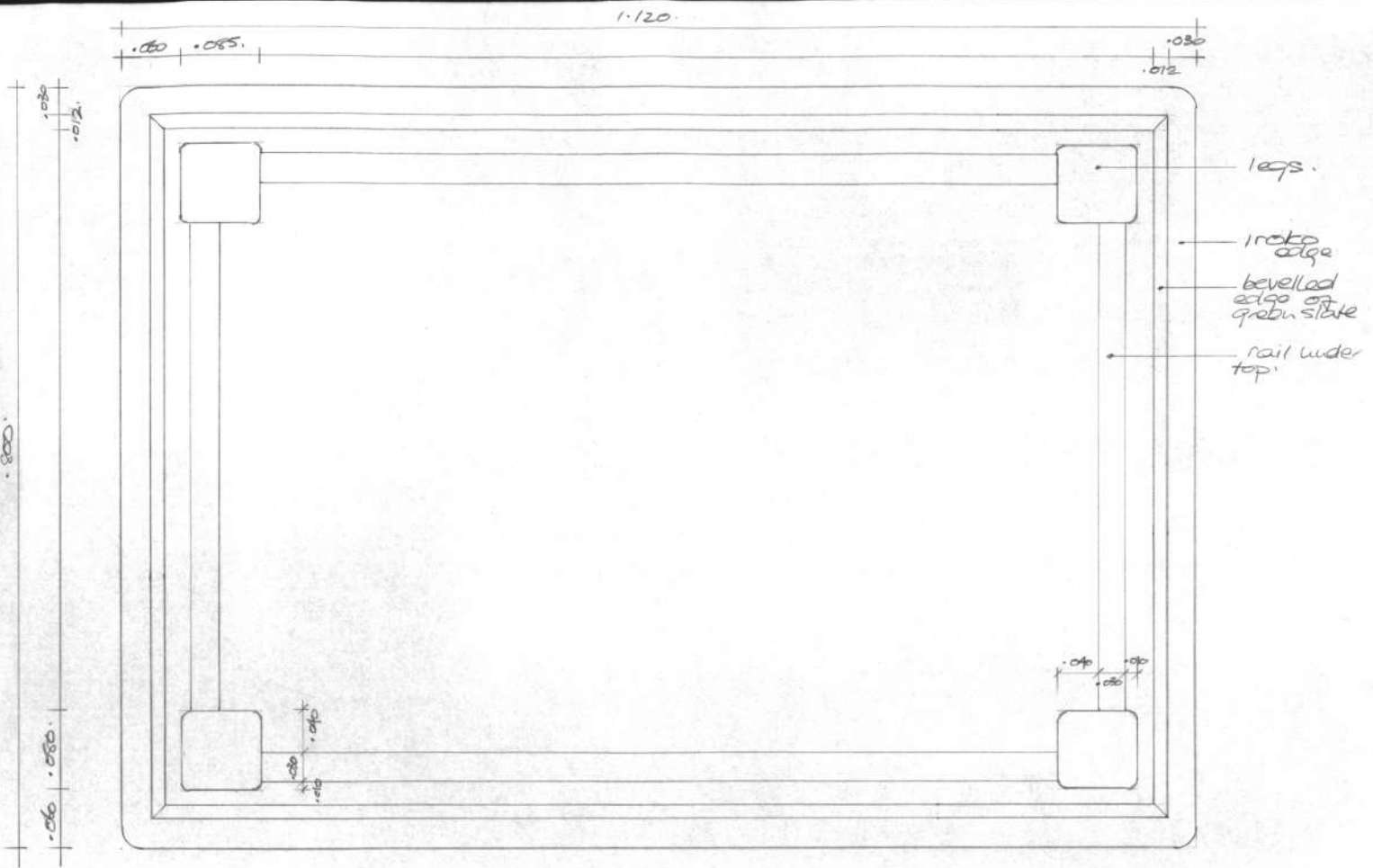

PLAN / PLAN SECTION
TABLE NEBSORE

Scale: 1:5.
date: NOV '88.

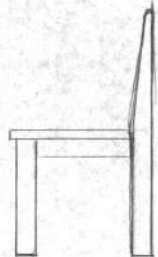
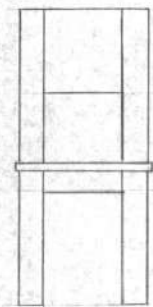
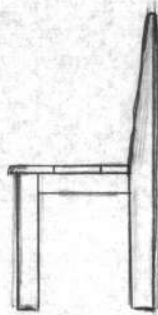
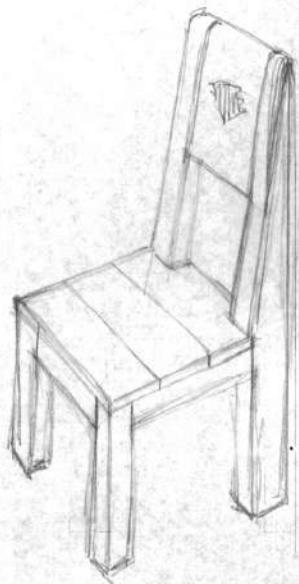

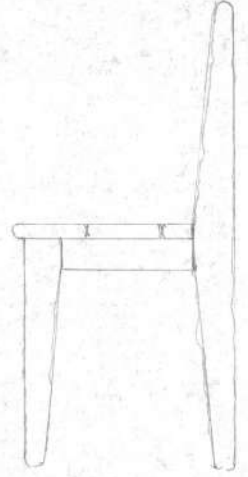
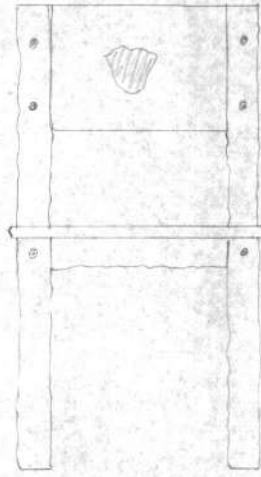
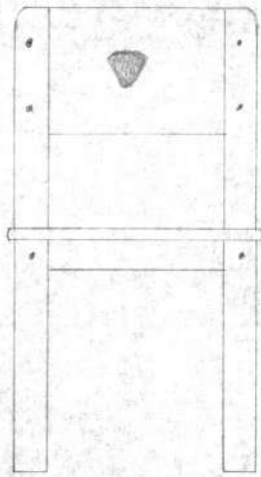
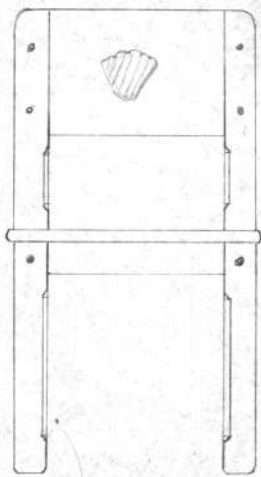

? chamfer
with edge
only
NO?

Rustic Chair
Scale 1:10
Nov '86.

92 bk
46 st.
55 front w.
41 rear w.
40 dp.

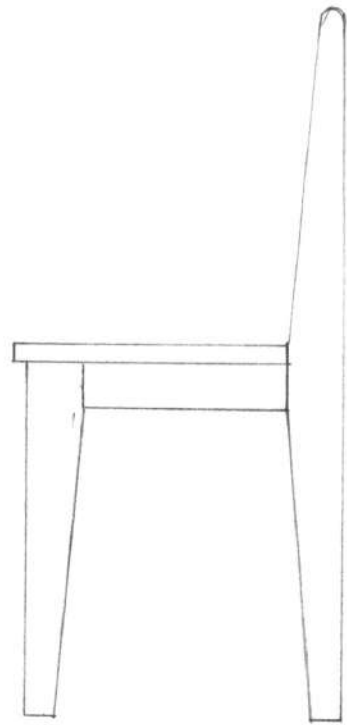
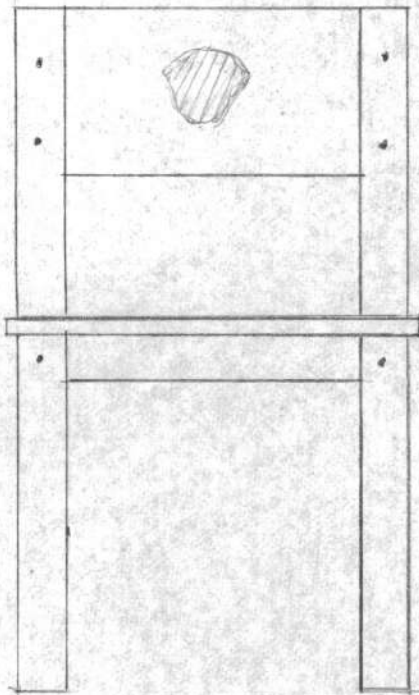

Dimensioned drawing.

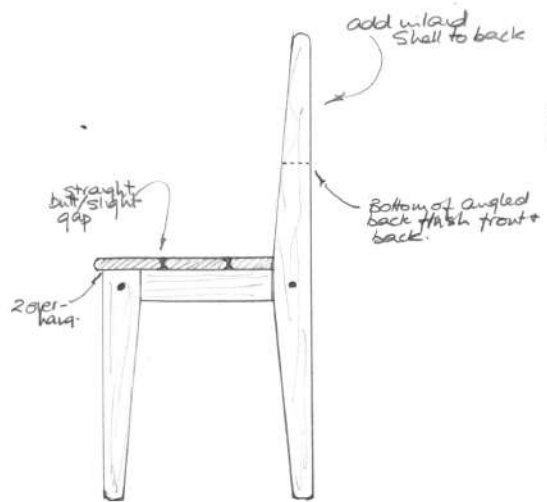
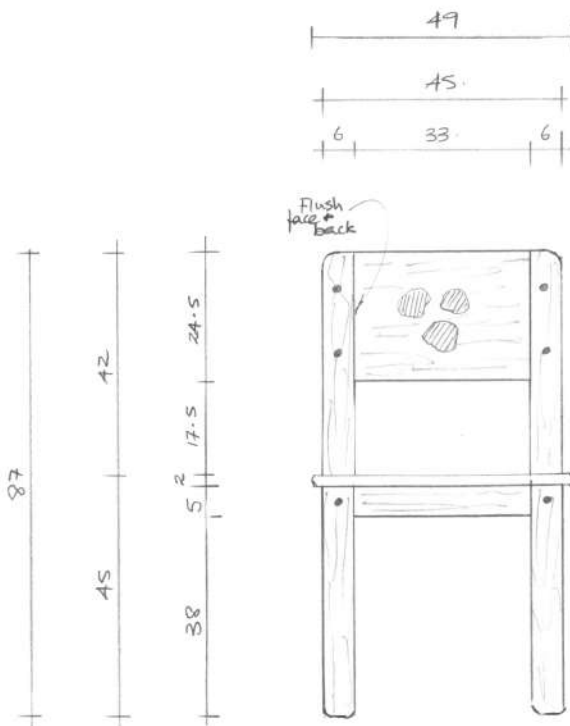

NB. - all inclined lines / some angle.

Round - slightly crudely all edges.

Soften edge before gluing pieces (make joints not perfect fit).

? Roger re: weight.

Rustic chair

Scale 1:10.
Nov '86

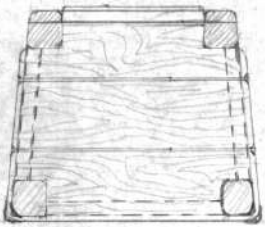

Note: Slightly crudely
showing dowels (x)
wire brush softer grain
or sandblast
black and stain to mid
blast silver grey
insert flat shell.

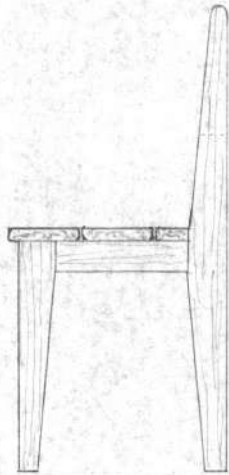
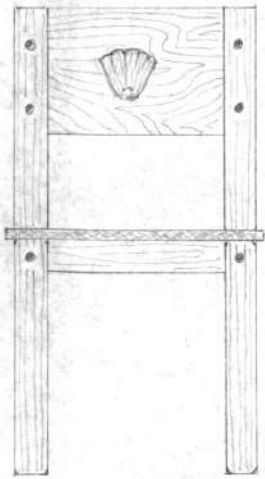

Rustic Chair
Scale 1:10.
Nov '86

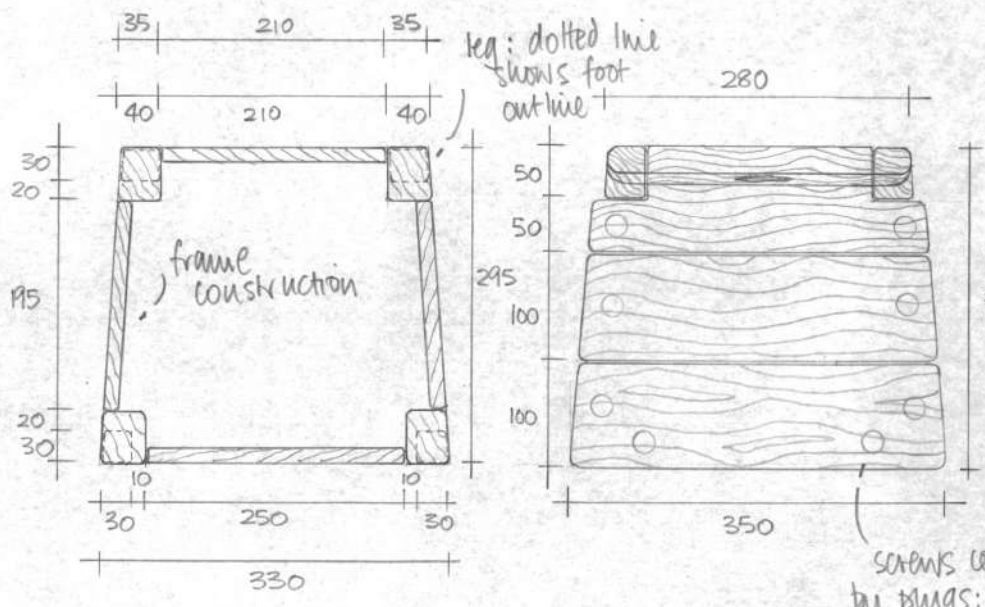

- make chair slightly crudely, show dowels.
- wirebrush softer grain to achieve drift wood effect.
- bleach and stain silver grey
- inlay flat shell.

screws concealed by plugs: grained.

CHILD'S OYSTER CHAIR
1:5 NOV '91



- Round edges before gluing to emphasise joints.

